

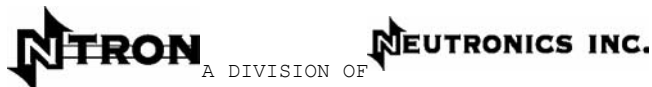
*Engineered Solutions for Gas Detection and Analysis*

**High Purity Instruments**

**MODEL 5124BE-N1-WO**

OXYGEN ANALYZER - PERCENT RANGE  
WITH REMOTE SENSOR MODULE  
**INSTALLATION MANUAL**

File Name: MN-A-0177  
Manual Part Number: 5-06-4900-65-0  
Revision Level: A Revision Date: 8/19/08  
ECO: 8541



456 Creamery Way, Exton, PA 19341

Phone: 610.524.8800 • Fax: 610.524.8807 • Email: [info@neutronicsinc.com](mailto:info@neutronicsinc.com)  
[www.neutronicsinc.com](http://www.neutronicsinc.com)



# Table of Contents

<b>TABLE OF CONTENTS.....</b>	<b>3</b>
<b>FOR YOUR SAFETY:.....</b>	<b>4</b>
<b>THANK YOU FOR PURCHASING THE MODEL 5124BE-N1-WO ANALYZER FOR ZERO TO 25 % RANGE OXYGEN MEASUREMENT. ....</b>	<b>5</b>
<b>1        CHAPTER 1 – INTRODUCTION AND OVERVIEW .....</b>	<b>6</b>
<b>2        CHAPTER 2 – SYSTEM INSTALLATION AND START-UP.....</b>	<b>8</b>
STEP 1 – ANALYZER INSTALLATION .....	9
STEP 2 – SENSOR INSTALLATION .....	10
STEP 3 – ELECTRICAL INSTALLATION .....	12
<b>3        CHAPTER 3 – OPERATING INSTRUCTION .....</b>	<b>21</b>
A. FIRST TIME POWER UP.....	21
B. NORMAL POWER UP AND POWER DOWN INSTRUCTIONS.....	23
C. OXYGEN ALARM LEVEL SETTINGS.....	23
D. FEATURES .....	24
<i>Temperature OK Relay</i> .....	24
<i>Fault Relay</i> .....	24
<i>Oxygen Alarm 1 &amp; Alarm 2 Relays</i> .....	25
<i>Analog Voltage &amp; Analog Current Output</i> .....	26
<i>Range ID Voltage</i> .....	26
<i>RS-232 Port</i> .....	27
<b>4        CHAPTER 4 – MAINTENANCE AND TROUBLESHOOTING.....</b>	<b>29</b>
<b>5        CHAPTER 5 – SPECIFICATIONS **** .....</b>	<b>31</b>
WARRANTY .....	33
INTENDED USE FOR THE MODEL 5124BE-N1-WO .....	34
APPENDIX A: AMBIENT AIR CALIBRATION.....	35
APPENDIX B: SYSTEM FAULTS.....	38
APPENDIX C: OXYGEN ALARM LEVEL SETTINGS .....	40
APPENDIX D: RS-232 PORT.....	42
APPENDIX E: SYSTEM SETUP .....	44
APPENDIX F – SPARE PARTS LIST.....	46
APPENDIX G – MSDS MATERIAL SAFETY DATA SHEET .....	47
APPENDIX H – DECLARATION OF CONFORMITY .....	48
APPENDIX I – DECOMMISSIONING THE MODEL 5124BE-N1-WO ANALYZER.....	49

## For Your Safety:



**PLEASE READ THIS MANUAL IN ITS ENTIRETY BEFORE ATTEMPTING INSTALLATION OR OPERATION! Attempting to operate the Model 5124BE-N1-WO without fully understanding its features and functions may result in unsafe conditions.**

- Always use protective eye wear and observe proper safety procedures when working with pressurized gases.
- Always assure the pressure of gas entering the Model 5124BE-N1-WO sensor is 1-10 psig.
- Always calibrate the Model 5124BE-N1-WO at an equivalent pressure and flow rate to the measured gas. Maximum pressure should not exceed 10 psig.
- Always allow the Model 5124BE-N1-WO to cool down before attempting to access the sensor.
- Never expose the Model 5124BE-N1-WO analyzer or the remote sensor chassis to water, high humidity or moisture. The analyzer chassis is not watertight.
- Never expose the Model 5124BE-N1-WO analyzer or the remote sensor to flame or high temperatures.
- Never expose the Model 5124BE-N1-WO analyzer or the remote sensor to flammable gases or vapors. The unit is not rated Explosion Proof, or Intrinsically Safe.
- Never expose the Model 5124BE-N1-WO sensor module directly to unregulated gas lines, cylinder gas. High gas pressures may cause the sensor components to rupture.
- Ensure the analyzer and the remote sensor unit is mounted in an area of free airflow to prevent the chassis from exceeding the operating temperature specifications. Do not mount the analyzer against hot surfaces. Do not block the ventilation louver on the analyzer chassis.

**Thank you for purchasing the Model 5124BE-N1-WO Analyzer for zero to 25 % range Oxygen measurement.**

The Model 5124BE-N1-WO Compact Analyzer is a user friendly, microprocessor controlled Oxygen measuring instrument. It has many features to offer the user, which will be described in this manual. We require that all personnel who use the instrument read this manual to become more familiar with its proper operation.

For further detail regarding the maintenance and in-field service of the Model 5124BE-N1-WO analyzer, please contact the Neutronics Inc. Customer Service Department. If you have questions or comments, we would like to hear from you.

Neutronics Inc. Customer Service Department  
456 Creamery Way  
Exton, PA 19341  
Tel: (610) 524-8800  
Toll Free: (800) 378-2287 (US only)  
Fax: (610) 524-8807

EMAIL: [info@neutronicsinc.com](mailto:info@neutronicsinc.com)  
Visit us at [www.neutronicsinc.com](http://www.neutronicsinc.com)

**Equipment Serial Number: \_\_\_\_\_**

(For faster service, please have this number ready if for any reason you need to contact us about your instrument)

Copyright ©2008 Neutronics Inc.

This work is protected under Title 17 of the US Code and is the sole property of Neutronics Inc. No part of this document may be copied or otherwise reproduced, or stored in any electronic information retrieval system, except as specifically permitted under US copyright law, without the prior written consent of Neutronics Inc.

# 1

## CHAPTER 1 - INTRODUCTION AND OVERVIEW

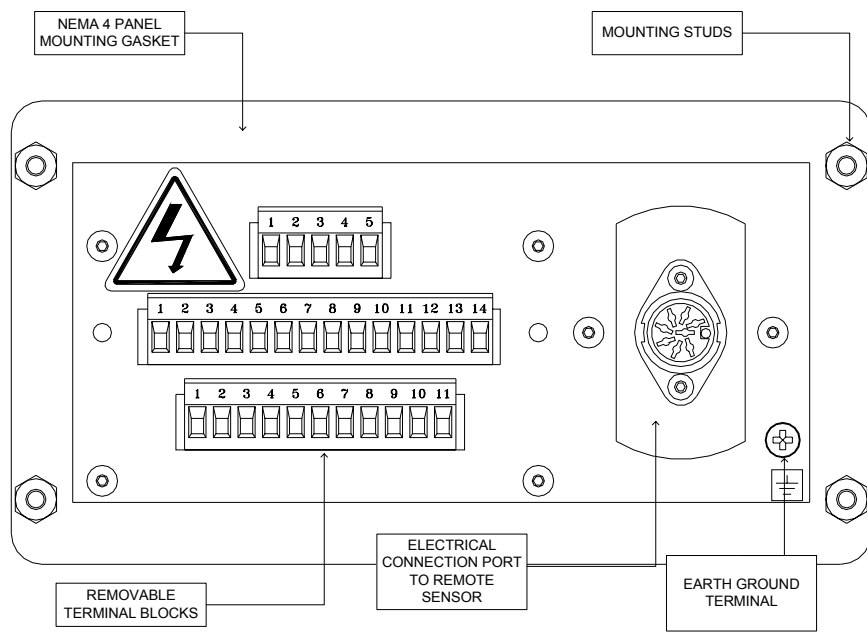
The Model 5124BE-N1-WO analyzer is a microprocessor-based instrument for measuring percent level oxygen in an inert gas background.

The analyzer is based on an amperimetric zirconium oxide remote sensor. This sensor assures reliability and fast response for oxygen concentration measurements, in inert gas backgrounds, in the percent range. The solid-state sensor offers long life with little maintenance. The sensor is not affected by dry atmospheres or by extremely cold storage temperatures. It also has a very long storage life.

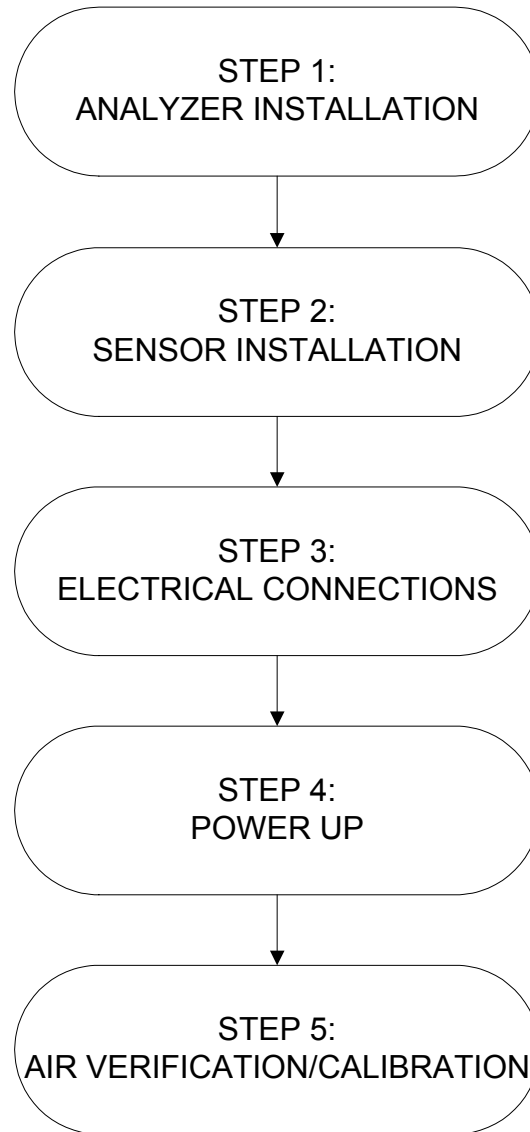
The sample gas is flowed through a self-contained external sensor housing. The pneumatic connections are made to the 3/4"-16 male threaded port for ease of use.

The Model 5124BE-N1-WO analyzer is designed to be flush-mounted to a panel or console. Because of its small size, the analyzer can be integrated into a variety of equipment or control panels. Some of the analyzer features include:

- Compact, rapid-response external Zirconia oxygen sensor module
- Two User-adjustable oxygen Alarms with configurable relay outputs for process control use.
- One System Fault relay output.
- One Temperature OK relay output.
- 4-20 mA Analog Current Output, range configurable.
- 0-1/5/10 VDC Analog Voltage Output, range configurable.
- 0-10V Range Identification Voltage to be used with the Analog Outputs
- RS-232 Serial Interface Port.



**Figure 1 - Model 5124BE-N1-WO Rear View**

**2****CHAPTER 2 - SYSTEM INSTALLATION AND START-UP****Figure 2 - Power Up Sequence**



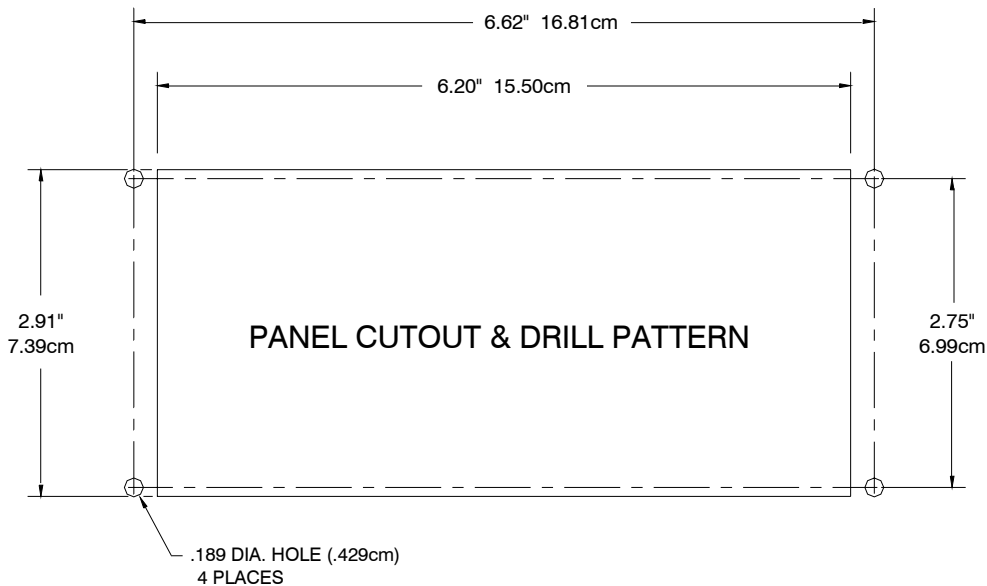
## Step 1 - Analyzer Installation



**WARNING:** The internal components of the Model 5124BE-N1-WO analyzer and the remote sensor are fragile. Do not drop the analyzer or the remote sensor during installation. Do not expose the unit to shock or vibration during installation. Failure to comply may damage the fragile components inside the analyzer and remote sensor may result in loss of warranty.

The Model 5124BE-N1-WO analyzer is designed to be mounted flush to the surface of an equipment control panel. Observe the following guidelines when installing the analyzer:

- Allow ample space at the rear of the analyzer for easy access to all electrical and pneumatic connections.
- Be sure that the analyzer will not be exposed to water, adverse temperature, or shock.
- Be sure that the analyzer has free air flow around the vent slots on the chassis to prevent overheating.



**Figure 3 - Analyzer Panel Cutout Diagram**

## Step 2 – Sensor Installation

All pneumatic connections are to be made to the Model 5124BE-N1-WO remote sensor. The remote sensor is designed to be screwed-on in-situ to the process vessel at which the oxygen concentration measurements are to be made.

**Drill the Sample Port.** Locate the sample point on the process vessel at which the oxygen concentration measurements are to be taken. Drill a hole at the location. The size of the initial drill hole should be between 0.68" to 0.70" diameter depending on the wall thickness of the sample process vessel.

**Tap Engagement Threads to the Sample Port.** Using a 3/4-16 UNF-2A tap tool, tap the engagement threads to the sample port. If the process vessel wall is very thick, tap to a minimum depth of 0.5" to ensure proper engagement of the external sensor to the process vessel. Thoroughly clean both the sample port and process vessel of any burrs, slivers, or tap oils before installing the sensor.

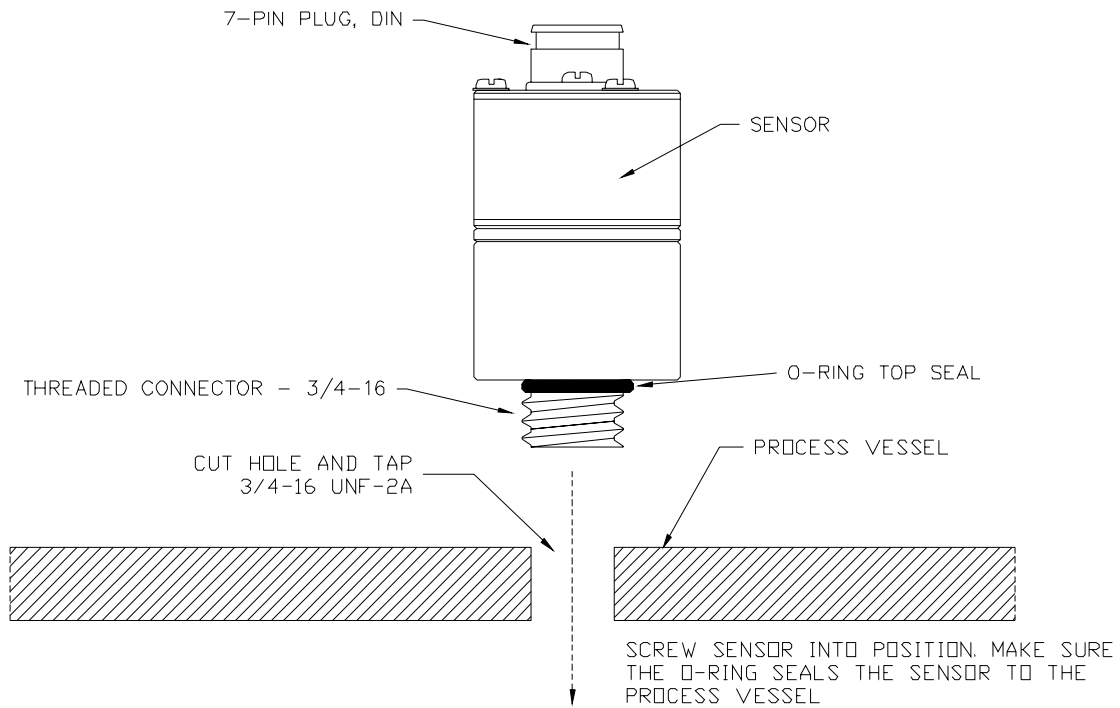
**Screw the Sensor to the Sample Port.** Once the sample port has been properly threaded and cleaned, screw the sensor to the sensor port. Make sure that the O-ring at the base of the external sensor port neck is properly compressed between the sensor body and the process chamber ball. Failure to comply will cause the process gas to leak into the atmosphere.



**WARNING:** The external sensor is designed to measure oxygen concentrations in gas form in an inert gas background. If there are fluids in the process vessel, select a sample location at which the sensor will not be directly exposed to the fluid.

**WARNING:** The acceptable background gases for oxygen measurements are nitrogen and argon. Some gases will affect the accuracy of the sensor while others may damage the sensor permanently. Contact Neutronics if you are not sure about the affect of your process gases on the external sensor.

**WARNING:** Do not over pressurize the sample inlet port as this may permanently damage the internal components of the analyzer. Failure to comply may void the warranty.



**Figure 4 - Sensor mounting detail**

## Step 3 - Electrical Installation



**CAUTION:** Be sure all mains power supply is off before attempting the electrical connections to the analyzer and remote sensor. DO NOT WORK WITH LIVE WIRES! Do not leave any exposed wire at the connectors or cables. Before applying power, ensure terminal blocks are fully inserted into the mating connector at the analyzer.

**DANGER:** The Model 5124BE-N1-WO analyzer and its external sensor are not rated intrinsically safe or explosion proof. Be certain that no flammable gases are present in the areas where the analyzer and the external sensor will be installed.

**CAUTION:** The Model 5124BE-N1-WO analyzer and external housings are not rated waterproof. Do not mount the analyzer or the sensor in an area where it may contact water or other liquid elements.

**WARNING:** The Model 5124BE-N1-WO is not equipped with a circuit breaker. A disconnecting switch or a circuit breaker must be installed in series with the mains power to the analyzer.

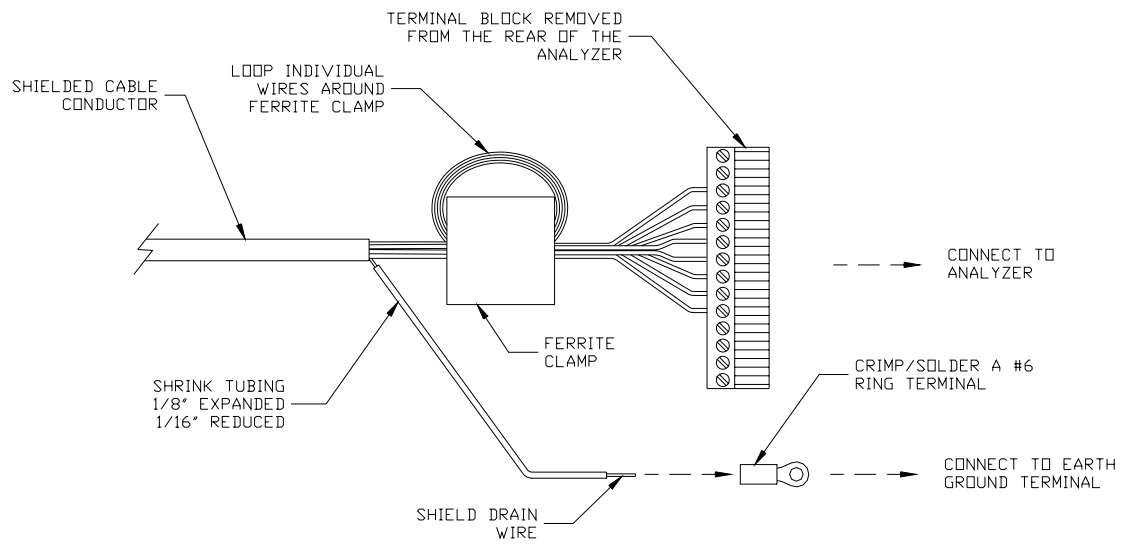
All electrical connections to the Model 5124BE-N1-WO analyzer is to be made to the three terminal blocks and sensor interface socket located at the back of the analyzer chassis. A label depicting the terminal block arrangement and the location of the bayonet connector is affixed to the top of the chassis as reference. The terminal blocks may be removed for wiring.

The electrical connection to the Model 5124BE-N1-WO external sensor is to be made to the analyzer interface socket. Use the sensor interface cable provided by Neutronics.



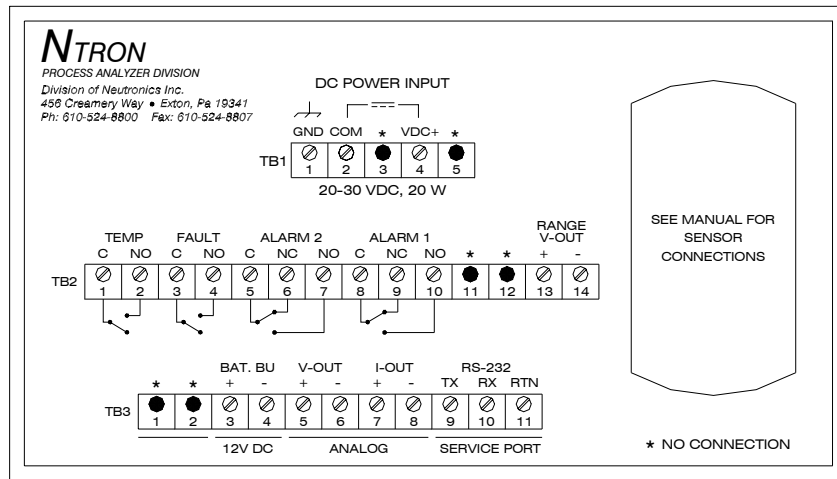
**CAUTION:** In order to comply with CE EN61326-1:2006 standards, all electrical connections to the three terminal blocks on the back of the analyzer are to be made using shielded cable conductors. Each electrical connection to the terminal blocks must be looped through the ferrite clamp provided. If more than one shielded cable conductor is used, the individual wires from the different cables may share the same ferrite clamp. Strip the cable jacket back about 8 inches to ensure all the individual wires fit through the ferrite clamp. Additional ferrite clamps may be purchased from Neutronics if necessary (See Appendix F: Spare Parts).

**CAUTION:** Also, in order to comply with CE EN61326-1:2006 standards, all shielded cable conductors must be earth grounded at both ends of the cable. The shield drain wire from the cable conductors must be connected to the earth ground screw terminal located at the back of the analyzer. It is also recommended that the exposed drain wire be covered with shrink tubing and the end be terminated with a #6 ring terminal before connecting it to the earth ground screw terminal. The recommended shrink tubing size is 1/8" expanded to 1/16" reduced. See Figure 5.

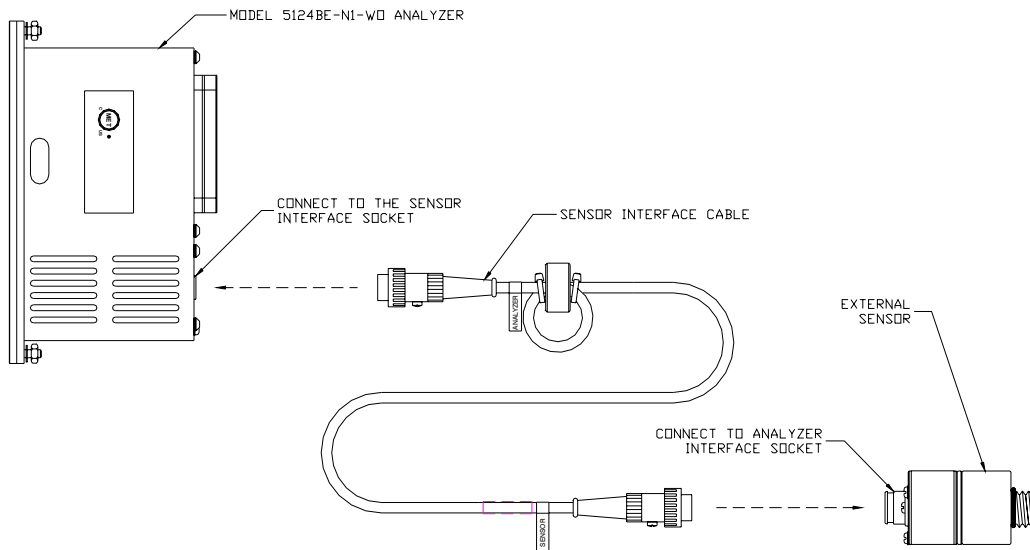


**Figure 5 - Recommended electrical connection to the analyzer terminal blocks**

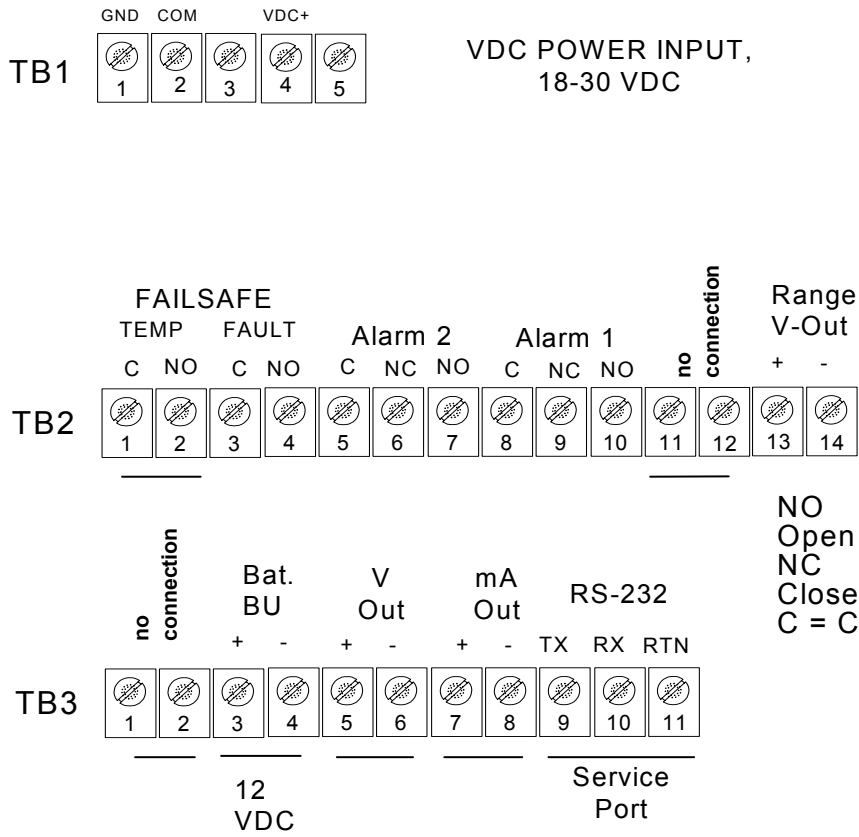
A label depicting the terminal block arrangement is affixed to the top of the chassis for easy reference during installation and maintenance. The terminal blocks feature screwed terminals. The terminal blocks are also removable for ease of wiring or removal of the analyzer module.



**Figure 6 - Model 5124BE-N1-WO Electrical Connections Label**



**Figure 7 - Sensor Interface Cable Connection**



**Figure 8 - Analyzer chassis electrical connections**

The following is a list of all possible electrical connections to the Model 5124BE-N1-WO analyzer:

**External Sensor Interface**

The Model 5124BE-N1-WO analyzer is electrically connected to the external sensor via the sensor interface cable. Each end of the sensor interface cable is labeled. The "ANALYZER" labeled end is to be connected to the sensor interface socket on the analyzer. The "SENSOR" labeled end is to be connected to the analyzer interface socket on the external sensor.



### Oxygen Alarm-1 Relay Output

Use 18-22 AWG, shielded cable for the connections. The shielded cable must be grounded at both ends to comply with EN61326-1:2006 specifications. Loop individual connectors around the ferrite clamp provided.

**Relay Type:** Form 1 C, SPDT, 5A @ 250 VAC, 5A @ 30VDC  
**Connections:** **Common:** Terminal Block TB2 Pin 8  
**Normally Closed Output:** Terminal Block TB2 Pin 9  
**Normally Open Output:** Terminal Block TB2 Pin 10

### Oxygen Alarm-2 Relay Output

Use 18-22 AWG, shielded cable for the connections. The shielded cable must be grounded at both ends to comply with EN61326-1:2006 specifications. Loop individual connectors around the ferrite clamp provided.

**Relay Type:** Form 1 C, SPDT, 5A @ 250 VAC, 5A @ 30VDC  
**Connections:** **Common:** Terminal Block TB2 Pin 5  
**Normally Closed Output:** Terminal Block TB2 Pin 6  
**Normally Open Output:** Terminal Block TB2 Pin 7

### System Fault Relay Output

Use 18-22 AWG, shielded cable for the connections. The shielded cable must be grounded at both ends to comply with EN61326-1:2006 specifications. Loop individual connectors around the ferrite clamp provided.

**Relay Type:** Form 1 B, SPST, 5A @ 250 VAC, 5A @ 30VDC  
**Connections:** **Common:** Terminal Block TB2 Pin 3  
**Normally Open Output:** Terminal Block TB2 Pin 4

### Temperature OK Relay Output

Use 18-22 AWG, shielded cable for the connections. The shielded cable must be grounded at both ends to comply with EN61326-1:2006 specifications. Loop individual connectors around the ferrite clamp provided.

**Relay Type:** Form 1 B, SPST, 5A @ 250 VAC, 5A @ 30VDC  
**Connections:** **Common:** Terminal Block TB2 Pin 1  
**Normally Open Output:** Terminal Block TB2 Pin 2

### Range ID Output

Use the Range ID voltage with either the analog voltage or the analog current output to identify the full span oxygen concentration measurement. Use 20-26 AWG, shielded cable for the connections. The shielded cable must be grounded at both ends to comply with EN61326-1:2006 specifications. Loop individual connectors around the ferrite clamp provided.

**Output Voltage:** 0 - 10 Volts DC

**Connections:**     **Voltage + Output:** Terminal Block TB2 Pin 13  
                      **Voltage - Output:** Terminal Block TB2 Pin 14

### Analog Voltage Output

The analog voltage output is factory pre-set to be either 0-1, 0-5, or 0-10 volts. Use 20-26 AWG, shielded cable for the connections. The shielded cable must be grounded at both ends to comply with EN61326-1:2006 specifications. Loop individual connectors around the ferrite clamp provided.

**Output Voltage:** 0 - 1, 0 - 5, or 0 - 10 Volts DC

**Connections:**     **Voltage + Output:** Terminal Block TB3 Pin 5  
                      **Voltage - Output:** Terminal Block TB3 Pin 6

### Analog Current Output

The analog current output is a negative ground, non-isolated 4-20 mA current loop. Use 20-26 AWG, shielded cable for the connections. The shielded cable must be grounded at both ends to comply with EN61326-1:2006 specifications. Loop individual connectors around the ferrite clamp provided.

**Output Voltage:** 4 - 20 mA

**Maximum Loading:** 250 ohms

**Connections:**     **Current + Output:** Terminal Block TB3 Pin 7  
                      **Current - Output:** Terminal Block TB3 Pin 8

### Battery Backup (Optional)

These terminals may be used to connect the Model 5124BE-N1-WO analyzer to a 12V battery backup system such as a lead acid battery. Battery backup function is not required for normal operations.

**Input Voltage:** 12 volts nominal

**Connections:**     **Battery + Terminal:** Terminal Block TB3 Pin 3  
                      **Battery - Terminal:** Terminal Block TB3 Pin 4

### RS-232 Service Port

The RS-232 Service Port is used for interfacing with any standard PC computer via the communications serial port. Use 20-26 AWG, shielded cable for the connections. The shielded cable must be grounded at both ends to comply with EN61326-1:2006 specifications. Loop individual connectors around the ferrite clamp provided.

<b>SIGNAL DESIGNATION AT ANALYZER</b>	<b>ANALYZER TB2 CONNECTION</b>	<b>SIGNAL DESIGNATION AT COMPUTER</b>	<b>COMPUTER DB9 SERIAL PORT CONNECTION</b>
TX	Pin 9	RX	Pin 2
RX	Pin 10	TX	Pin 3
RTN	Pin 11	RTN	Pin 5

### Mains Power

Use 18-22 AWG, shielded cable for the connections. The shielded cable must be grounded at both ends to comply with EN61326-1:2006 specifications. The ground shielding at the analyzer end is to be connected to terminal block TB1 pin 1. Loop individual connectors around the ferrite clamp provided.

**Mains Power Voltage:** 18 - 30 Volts DC  
**Connections:** **DC +:** Terminal Block TB1 Pin 4  
**DC -:** Terminal Block TB1 Pin 2  
**Earth/Shield Ground:** Terminal Block TB1 Pin 1



**WARNING:** Do not apply mains power to the analyzer or the analyzer until all the electrical and pneumatic connections to the analyzer and the remote sensor have been properly installed.



# 3

## CHAPTER 3 - OPERATING INSTRUCTION

### A. First Time Power Up

The Model 5124BE-N1-WO analyzer and its remote sensor are shipped ready to use, right from the carton. Its default configuration has been set to your application. Review the default configuration settings, as shown in the analyzer software setup log sheet, shipped with your Model 5124BE-N1-WO analyzer. Before commissioning your system, ensure that the default settings match your application. Contact the factory if your default settings do not match your application.



**WARNING:** Do not apply mains power to the analyzer until all the electrical and pneumatic connections to the analyzer and remote sensor have been properly installed.

### FIRST TIME POWER UP CHECK LIST

**Have you:**

- Verified that all the electrical and pneumatic connections to the Model 5124BE-N1-WO analyzer have been properly installed?
- Ensured that none of the mains power wiring to the analyzer module is exposed?
- Mounted the analyzer and the remote sensor in areas where there are no flammable vapors?
- Mounted the analyzer and the remote sensor away from exposure to rain, dripping water, or hose down?
- Read this manual in its entirety?

**First Time Power Up Instructions**

1. **Apply Ambient Air to the External Sensor Sample Port:** Apply clean, dry oil-free ambient air to the process vessel. See the analyzer installation manual for more detail. Regulate the ambient air supply in your process vessel to match process conditions. Do not exceed 10 PSI.
2. **Apply Mains Power:** Apply mains power to the analyzer. The Model 5124BE-N1-WO analyzer will perform the following power up sequence:
  - a. **Identification (Verify):** The analyzer will display “@@@” on the RS-232 terminal to indicate that it is powering up. After that, it will display the model number, the serial number, the software version and the RS-232 baud rate on the RS-232 terminal.
3. **Wait 1 Minute for Sensor to Warm Up to Operating Temperature:** Upon completing the power up sequence, the Model 5124BE-N1-WO will bring up the sensor heater temperature to the operating temperature. This process will take about 1 minute. During this period the RS-232 terminal will display data stream below. Note that the numbers to the right of the “RUN” column are the warm-up countdown numbers in seconds:

```
...  
RUN 56.7 % FLT 1,2  
RUN 55.6 % FLT 1,2  
RUN nr % FLT 1,2  
RUN nr % FLT 1,2  
RUN 52.5 % FLT 1,2  
RUN 51.5 % FLT 1,2  
RUN nr % FLT 1,2  
RUN nr % FLT 1,2  
RUN 48.3 % FLT 1,2  
RUN 47.3 % FLT 1,2  
...
```

4. **Temperature Stabilization:** After completion of the warm-up sequence, the analyzer is ready for calibration and oxygen measurements. However, it is recommended that the user wait for an additional 45 minutes for the system to reach temperature stabilization for the most accurate calibration and measurements. Typically, the RS-232 terminal will display the following data stream:

```
...  
RUN 20.9 % ALM1 ALM2 FLT 5,11  
RUN 20.9 % ALM1 ALM2 FLT 5,11  
RUN 20.9 % ALM1 ALM2 FLT 5,11  
RUN 20.9 % ALM1 ALM2 FLT 5,11  
RUN 20.9 % ALM1 ALM2 FLT 5,11  
RUN 20.9 % ALM1 ALM2 FLT 5,11  
...
```

5. **Measure Air Sample (Verify):** After temperature stabilization, if the Model 5124BE-N1-WO analyzer indicates between 20.8% and 21.0% at ambient air, calibration is not necessary. Otherwise, verify that clean, dry, oil-free ambient air is supplied and regulated as required in step 1. If the sample air supply requirements are met and the reading is not within the stated tolerance, perform air calibration per Appendix A.
6. **Verify Outputs:** If the Model 5124BE-N1-WO analyzer indicates between 20.8% and 21.0% after warm-up, and all the first time power-up verifications have been completed, Check the fault, temperature OK, and oxygen alarm relay contacts to ensure that they are wired properly and functioning normally. Also, check the analog current, analog voltage, and range ID voltage outputs to ensure that they are functioning normally.
7. **Apply The Gas To Be Analyzed:** Apply the gas that is to be analyzed to the analyzer. Verify that the oxygen concentration readout on the RS-232 terminal, relay contact outputs, the analog outputs and the Range ID outputs are wired properly and functioning normally.

## **B. Normal Power Up and Power Down Instructions**

After the instructions for the first time power up has been completed, the Model 5124BE-N1-WO analyzer can be run continuously. For periods when the analyzer is not in use, it may be powered down. Wait at least 15 minutes after power down to ensure that the sensor is cool before reapplying power to the analyzer.

## **C. Oxygen Alarm Level Settings**

If the user's process requires adjustments to either oxygen alarm level, follow adjustment procedure in Appendix C.

## D. Features

The Model 5124BE-N1-WO analyzer is intended to be used to measure oxygen concentrations in inert background. The analyzer comes equipped with several operational features. Each feature will be discussed in detail separately:

- Four relay outputs: TEMPERATURE OK, FAULT, ALARM 1 and ALARM 2.
- Three outputs: Analog Current, Analog Voltage & Range ID voltage.
- RS-232 Output

### Temperature OK Relay

The Temperature OK relay is activated when the Model 5124BE-N1-WO analyzer is heating up the sensor to its operating temperature. Once the sensor reaches the operating temperature, the relay de-activated.

Sensor Heater Temperature	Normally Open Relay Output
At operating temperature	Open **
Not at operating Temperature	Closed **

\*\* The temperature ok relay operates in fail-safe mode.

### Fault Relay

The fault relay is activated when the Model 5124BE-N1-WO Analyzer detects one or more system faults. Refer to Appendix B for a description of the system faults. Refer to the following table for the outputs of the fault relay:

System Fault Status	Normally Open Relay Output
Active	Open **
Not Active	Closed **

\*\* The fault relay operates in fail-safe mode.



## Oxygen Alarm 1 & Alarm 2 Relays

The Oxygen Alarm 1 and Alarm 2 relay activation depend on the following Model 5124BE-N1-WO Analyzer settings. Refer to the software setup log shipped with the analyzer to determine your actual settings.

- ◆ **Alarm Set point:** Alarm Set point is the oxygen concentration at which the oxygen alarm relays activate or de-activate. To adjust alarm set point, see Appendix C.
- ◆ **Descending:** The Descending setting determines if the oxygen alarm relays are activated above or below the alarm set point. If the Descending setting is set to "yes", the alarm relays and LEDs activate when the oxygen concentration is below the alarm set point concentration. If the Descending setting is set to "no", the alarm relays activate when the oxygen concentration is above the alarm set point concentration. To adjust this setting, see Appendix E.
- ◆ **Failsafe:** The Failsafe setting determines the status of the alarm relays when the oxygen alarm is active. If the Failsafe setting is set to "yes", the alarm relays are de-energized when the oxygen alarm is active. If the Failsafe setting is set to "no", the alarm relays are energized when the oxygen alarm is active. To adjust this setting, see Appendix E.

The following table summarizes all the possible states of the oxygen alarm relay output:

O2 Concentration Above/Below Alarm Set Point?	Descending?	Failsafe?	Alarm Relay Status	Alarm Relay Normally Open Output	Alarm Relay Normally Closed Output
Above	No	No	Active	Closed	Open
Above	No	Yes	Active	Open	Closed
Above	Yes	No	Not-Active	Open	Closed
Above	Yes	Yes	Not-Active	Closed	Open
Below	No	No	Not-Active	Open	Closed
Below	No	Yes	Not-Active	Closed	Open
Below	Yes	No	Active	Closed	Open
Below	Yes	Yes	Active	Open	Closed

## Analog Voltage & Analog Current Output

The analog voltage and analog current output produces either a voltage or a current output proportional to the measured oxygen concentration. For the analog voltage, the zero scale is always 0 volts. The full scale is programmed at the factory to be either 1, 5, or 10 volts. For the analog current output the zero scale output is 4 milliamperes and the full-scale output is 20 milliamperes.

The measurement scale is also preprogrammed at the factory to one of the following:

<b>ANALOG FULL SCALE</b>
1 PERCENT
10 PERCENT
25 PERCENT
AUTO RANGING

When the measurement scale is auto-ranging, the analog output automatically scales to the smallest relevant measurement range. For example, When the measured oxygen concentration is 9.9 percent, the analog output will scale to 0-10 percent. When the measurement increases to 11 percent, the analog output will rescale to 0-25 percent.

Use the Range ID voltage output to identify the active measurement scale.

## Range ID Voltage

The Range ID voltage is used to identify the oxygen concentration at which the analog voltage and analog current outputs are at their full scale. This information is useful if the analog outputs are set to auto-ranging.

The following is a list of all possible Range ID voltages. Actual measured voltage may be within +/- 0.2 volts of indicated voltage.

<b>RANGE ID VOLTAGE</b>	<b>ANALOG FULL SCALE</b>
5.63 VOLTS	1 PERCENT
6.25 VOLTS	10 PERCENT
6.88 VOLTS	25 PERCENT

## RS-232 Port

The Model 5124BE-N1-WO Analyzer port will transmit information to a host computer via the RS-232 port. The information includes the oxygen concentration, fault status and oxygen alarm status. For more information on the RS-232 communications, see Appendix D.



# 4

## CHAPTER 4 - MAINTENANCE AND TROUBLESHOOTING



**WARNING:** The Model 5124BE-N1-WO analyzer has no field-serviceable parts, with the exception of the sensor and sensor cable. Do not attempt to repair the unit. All repairs are to be performed either at the factory or at any of the certified service centers. Failure to comply will result in loss of warranty.

TASK	RECOMMENDED FREQUENCY		
	AT COMMISSIONING	EVERY YEAR	AS REQUIRED
Calibrate Sensor	√		√**
Verify Sensor	√****	√	√
Clean the analyzer chassis and display panel with soft cloth. Make sure the ventilation ports are clear.		√	√
Replace remote sensor			√* Every 2 Years
Service			√

\* Actual sensor life may vary according to measurement conditions. Contact factory for additional sensor life evaluations.

\*\* Air calibration is only required at commissioning or after the unit has been serviced for elevation compensation. Verify calibration is required at commissioning or after service.

\*\*\*\* It is recommended that the unit be verified at ambient air concentration two weeks after commissioning to ensure that the sensor is not contaminated. Re-calibrate if the sensor output has drifted after two weeks and monitor for another six weeks if drift occurs. If the output in air continually drifts for the eight-week period, call an approved service center.

### Troubleshooting

System faults should clear after the 1-minute sensor heating period, and two minutes after a calibration was performed. If fault persists, follow the fault identification procedure specified in Appendix B. Call an approved service center if assistance is still needed.

Unstable sensor: Exposure to cross-sensitive chemicals, such as hydrocarbons, has been known to cause erratic sensor output. To determine if a process substance is affecting the sensor, plumb pure nitrogen to the analyzer and purge. After 15 minutes, the displayed concentration should be more stable. Call an approved service center if assistance is still needed.

**Troubleshooting (continued)**

Contaminated sensor: Avoid the use of silicone-based lubricants and sealants in the sample stream. Contamination should be monitored at commissioning, as detailed in the maintenance table in this section of the manual.

**Approved Service Centers for the Model 5124BE-N1-WO Analyzer**

Neutronics, Inc. reserves the right to change the list of service centers without notice.

Service Department  
Neutronics, Inc.  
456 Creamery Way  
Exton, PA 19341  
U.S.A.

Email: [service@neutronicsinc.com](mailto:service@neutronicsinc.com)

Toll Free: 1-800-378-2287 (U.S.A. Only)

Phone: 610-524-8800 ext. 123 or 171 (Operator is ext. 100)

# 5

## CHAPTER 5 - SPECIFICATIONS \*\*\*\*

Revision A

Release Date: August 2008

<b>OXYGEN SENSOR</b>	External Miniature Zirconia Amperometric Sensor
<b>SIGNAL INTERFACE</b>	<p>Serial Service Port: Bi-directional RS-232</p> <p>Analog Voltage Output: 0-1, 0-5, or 0-10 VDC</p> <p>Analog Current Output: Non-isolated 4 - 20 mA, 12 VDC, negative ground, powered by analyzer, maximum electrical load 250 Ohms</p> <p>Range ID Voltage: 0 - 10 Volts DC</p>
<b>RELAY OUTPUTS</b>	<p>Alarm-1: Field Adjustable Form C (SPDT) Voltage-free, 5A @ 250 VAC, 5A @ 30 VDC. Configurable to fail-safe/non fail-safe and ascending/descending action</p> <p>Alarm-2: Field Adjustable Form C (SPDT) Voltage-free, 5A @ 250 VAC, 5A @ 30 VDC. Configurable to fail-safe/non fail-safe and ascending/descending action</p> <p>Fault: Non-adjustable Form B (SPST) Voltage-free, 5A @ 250 VAC, 5A @ 30 VDC, Fail-Safe action, non-configurable.</p> <p>Temperature OK: Non-adjustable Form B (SPST) Voltage-free, 5A @ 250 VAC, 5A @ 30 VDC.</p>
<b>DISPLAY RANGES</b>	None.
<b>MEASUREMENT RANGE</b>	0 - 25%
<b>ACCURACY OF MEASUREMENT RANGE</b>	$\pm 1.0$ % of measurement range
<b>LOWEST DETECTABLE LIMIT</b>	0.05% @ 0-25% measurement range

\*\*\*\* Neutronics, Inc, whose policy is one of continuous improvements, reserves the right to change the specifications and contents without notice

<b>RESPONSE TIME</b>	T <sub>90</sub> < 15 seconds
<b>WARM UP TIME</b>	60 seconds for sensor warm up, 45 minutes for temperature equilibrium.
<b>HUMIDITY</b>	0-95 % non-condensing
<b>OPERATING TEMPERATURE</b>	32-113° F (0-45° C)
<b>STORAGE TEMPERATURE</b>	23-149° F (-5-65° C)
<b>SAMPLE PRESSURE</b>	1-10 PSIG
<b>SAMPLE FLOW</b>	0.5 lpm min.
<b>POWER</b>	VDC Unit: 20 - 30 VDC, 13 Watts
<b>MECHANICAL</b>	Faceplate: Height 3.75" x Width 7.00" • NEMA 4 • IP66 Panel Cut-out: Height 2.91" x Width 6.20" Electronic Compartment: Height 2.81" x Width 5.98" x 3.60" Depth • NEMA 1 • IP20 External Sensor: Height 3.25" x Diameter 1.5" • NEMA 1 • IP20 Sensor Interface Cable: Length 122" (3 meters)
<b>WEIGHT</b>	Analyzer: 2 lbs (0.9 kg) Sensor: 0.8 lbs (0.4 kg)
<b>WARRANTY</b>	12-months from date of shipment

\*\* Using the Model 5124BE-N1-WO to measure oxygen concentrations above 95% will significantly reduce sensor life.

\*\*\*\* Neutronics, Inc, whose policy is one of continuous improvements, reserves the right to change the specifications and contents without notice.



## Warranty

Neutronics warrants to the original purchaser, that the Model 5124BE-N1-WO oxygen analyzer and remote sensor are free from defects in material and workmanship for a period of one (1) year from the date of shipment from Neutronics or from one of Neutronics' authorized dealers. Our liability will be limited to the repair or replacement, at our factory, of parts found to be defective within the warranty period, as determined by Neutronics. The parts will be repaired or replaced free of charge if shipped prepaid to the factory in the original shipping carton. This warranty is void if the product has been subject to misuse or abuse, including but not limited to: exposure to water, humidity, temperature, shock or pressure outside of the listed specifications, or has not been operated or installed in accordance with operating and maintenance instructions, for repairs which were not performed by Neutronics or by one of its authorized dealers, or if the identifying markings on the product label have been altered or removed.

The seller assumes no liability for consequential damages of any kind, and the buyer, by acceptance through purchase of this product, will assume all liability for the consequences of its use or misuse by the buyer, his employees, or others.

Neutronics reserves the right to use any materials in the manufacture, repair or service of the products and to modify the design as deemed suitable, in so far as these materials or modifications maintain the stated warranty.

It is the sole responsibility of the buyer / user to determine if this product is suitable for the intended application.

THESE WARRANTIES ARE EXCLUSIVE AND IN LIEU OF ALL OTHER WARRANTIES, EXPRESSED, OR IMPLIED INCLUDING WARRANTY OF MERCHANTABILITY, FITNESS FOR A PARTICULAR PURPOSE.

## **Intended Use For The Model 5124BE-N1-WO**

The Model 5124BE-N1-WO oxygen analyzer and remote sensor were designed to provide the trained operator with useful information relating to the concentration of oxygen. This information may be used in process control or to minimize possible hazardous conditions, which may be present in various processes. Before implementation, the user must fully understand the operation and limitations of this instrument as well as the application for its use. The responsibility for the proper application, operation, installation, and maintenance of the Model 5124BE-N1-WO oxygen analyzer and its remote sensor is the sole obligation of the trained operator. The purchaser is required to ensure operators are properly trained in the use of this unit as well as in the possible hazards associated with its use or with the intended application. The purchaser must ensure that all of the proper warnings, labels, instruction manuals, lock outs, redundant components, hazard analysis, and system validation have been completed and provided to the trained operator before implementation of the Model 5124BE-N1-WO instrument.

## Appendix A: Ambient Air Calibration

The Model 5124BE-N1-WO analyzer, along with its remote sensor is shipped from the factory fully calibrated for its operational measurement range. It may be necessary, however, to perform air calibration at commissioning to account for differences in atmospheric pressures at the installation site.

Air calibration is necessary after sensor replacement.

Air calibration can only be done through the RS-232 terminal. See Appendix D for the procedure to set up RS-232 terminal communications



**WARNING:** The ambient air calibration procedure is complicated, and should only be performed by trained technicians.

**CAUTION:** Before attempting this air calibration procedure, verify that clean, dry, oil-free ambient air is being supplied to the analyzer as required by this manual.

**CAUTION:** The Model 5124BE-N1-WO RS-232 serial communications do not have flow control. The serial output string will not pause while the calibration input commands are being entered into the analyzer. It is strongly recommended that the serial output string be paused while the calibration is being performed. Type the serial output string pause command slowly.

The following are the steps to the calibration procedure:

**Verify calibration is necessary:**

- **Start with the analyzer in run mode.** Verify on the RS-232 terminal that the serial output stream from the analyzer is indicating operations in the "RUN" mode. If there are system faults active, verify that not of the system faults may cause the calibration to be invalid. If necessary, contact factory for clarification on active system faults.
- **Flow ambient air into the process chamber.**
- **Allow fifteen minutes for the sensor to stabilize.**
- **Observe the display for one minute.** If the display drifts more than 0.2%, over the one-minute period, check the ambient air source for contaminants such as a nearby nitrogen vent.
- **Determine calibration is necessary:** If the analyzer display reads 21.0% or greater, or the analyzer displays 20.8 or less, then calibration is necessary.

- **If calibration is not necessary:** Disconnect ambient air or calibration gas source from the analyzer. Apply process gas that is to be analyzed to the analyzer.

**Calibration procedure:**

- **Reset the analyzer RS-232 serial input buffer:** Press the "enter" key once to reset the serial buffer. The analyzer will indicate that the serial buffer is empty by sending an asterisk character "\*". See example below:

```
...  
RUN 20.9 % ALM1 ALM2 FLT 5,11  
RUN 20.9 % ALM1 ALM2 FLT 5,11  
  
*RUN 20.9 % ALM1 ALM2 FLT 5,11  
RUN 20.9 % ALM1 ALM2 FLT 5,11  
RUN 20.9 % ALM1 ALM2 FLT 5,11  
...
```

- **Pause RS-232 serial output stream:** Carefully type the following command string: "sserfmt=0" and press "enter". The serial output stream should stop. If the serial output stream does not stop, reset the serial input buffer again and retype the command string. Also note that the input characters will be mixed in with the output characters on the RS-232 terminal. See example below

```
...  
RUN 20.9 % ALM1 ALM2 FLT 5,11  
RUN 20.9 % ALM1 ALM2 FLT 5,11  
RUN 20.9 % ALM1 ALM2 FLT 5,11  
sSERfRUN 20.9 % ALM1 ALM2 FLT 5,11  
mtRUN 20.9 % ALM1 ALM2 FLT 5,11  
=0  
  
*
```

- **Perform Air Calibration:** Type the following command string: "scalibrate=0.209" and press "enter". If the calibration is successful, the analyzer will display another asterisk "\*" character. See example below:

```
*scalibrate=0.209  
  
*
```

- **Restart the RS-232 serial output stream:** Type "sferfmt=1" to restart the RS-232 serial output stream. The analyzer will resume its timed serial output. See example below:

```
*sferfmt=1  
  
*RUN 20.9 % ALM1 ALM2 FLT 5,11  
RUN 20.9 % ALM1 ALM2 FLT 5,11  
RUN 20.9 % ALM1 ALM2 FLT 5,11  
RUN 20.9 % ALM1 ALM2 FLT 5,11  
RUN 20.9 % ALM1 ALM2 FLT 5,11
```

- **Disconnect calibration gas:** Disconnect ambient air or calibration gas source from the analyzer. Apply the gas that is to be analyzed to the analyzer.

## Appendix B: System Faults

If the Model 5124BE-N1-WO Analyzer detects one or more system faults, it will display the fault code number on the RS-232. The analyzer will first indicate that there is at least one fault active by displaying the string "FLT". It will then display all the active faults by displaying all the fault code numbers separated by commas.

The following is a description of all the system fault code digits and its troubleshooting guide:

- **"1" - Sensor is warming up:** This system fault is active when the Model 5124BE-N1-WO analyzer is heating the sensor its operating temperature during the first minute of power up. All system outputs are not valid, except RS-232 output. No troubleshooting required. This system fault will clear itself when the sensor heater reaches operating temperature. This fault will clear typically after 1 minute.
- **"5" - Analog Output Overflow:** The measured oxygen concentration is higher than the span concentration of the analog voltage and current outputs. The analog output will be at full scale. Only the analog outputs are not valid. All other outputs are valid. For most instances, no troubleshooting is required. The fault will clear itself when your process gas is introduced to the analyzer. However, if this fault is experienced under process gas conditions, check the software setup log sheet to ensure that your analog output span setting is high enough to include all your process gas concentrations conditions. Your process gas concentration may also be larger than normal.
- **"6" - Analog Output Underflow:** The measured oxygen concentration is lower than the zero concentration of the analog voltage and current outputs. The analog output will be at zero scale. Only the analog outputs are not valid. All other outputs are valid. **Note:** This system fault condition can happen only on special custom units. This system fault cannot be remedied in the field. Contact the factory or an approved service center if this system fault code persists.
- **"8" - Reading Not Available:** The analyzer electronics has not produced a valid oxygen measurements. This may happen during power up, or during partial electronics failure. All analyzer outputs are not valid, except RS-232 output. If this system fault condition does not clear itself within minutes after power up, both the analyzer and the analyzer must be returned to the factory or an approved service center for servicing.

- **"10" - Check Sensor:** The analyzer has detected an invalid output from the external sensor. This may be caused by either the sensor being disconnected from the analyzer, or by a possible lead breakage inside the sensor housing. The lead breakage may have been caused by the sensor being dropped. All analyzer outputs are not valid, except RS-232 output. Check the electrical connections to the sensor. Verify that the sensor cable is properly connected to both the analyzer and the sensor housing. If all the electrical connections are sound, perform an air verification as shown in Appendix A. If the sensor output in air is off by more than +/-5%, replace sensor.
- **"11" - Non-Native Display Range:** The analyzer is measuring an oxygen concentration that is either higher or lower than the display range. For example, if the Display Range is set to 0-25% Fixed and the analyzer measures 30% oxygen, Fault 11 will activate. All output, with the exception of the analog voltage and analog current outputs, are valid. Fault 11 will be deactivated when the oxygen concentration measured by the analyzer returns to the selected display range.
- **"15" - Bad Calibration:** The Model 5124BE-N1-WO analyzer detected bad calibration data. This may be caused either by using a calibration gas that is not ambient air or the oxygen sensor inside the analyzer is damaged. If this system fault code is not cleared after repeating the air calibration, return the analyzer to the factory or an approved service center for servicing.
- **"18" - Check Sensor:** The analyzer has detected an extremely low output from the external sensor. This may be caused by one of the following conditions:
  - Depleted sensor
  - Sensor heater inoperable (heater burned out/no power to heater)
  - Insufficient zero gas flow to the sensor
  - Bad sensor cable

All analyzer outputs may or may not be valid, except RS-232 output is valid. Check the purge gas flow to the process chamber to ensure that it is sufficient. If the purge gas flow is sufficient, perform an air verification as shown in Appendix A. If the sensor output in air is off by more than +/-5%, replace sensor. If the oxygen concentration reported is not within 0.2%, then re-calibrate the analyzer as detailed in Appendix A. System Fault 18 low oxygen measurements may be disabled from the System Setup Menu (See Appendix E).

## Appendix C: Oxygen Alarm Level Settings

The Model 5124BE-N1-WO Analyzer is shipped from the factory with the oxygen alarm level set to your desired process. However, the oxygen alarm level settings may be changed using the procedures below.



**WARNING:** Altering the Oxygen Alarm Level setting may affect the Model 5124BE-N1-WO analyzer's performance in your process.

**WARNING:** Altering the Oxygen Alarm Level setting does not alter the factory default settings. If a Factory Restore function is performed (see Appendix E), the Oxygen Alarm Level setting will revert back to the one programmed at factory. It is best to have your desired Oxygen Alarm Level settings be programmed at the factory.

The following are the steps to change Alarm 1 level setting:

- **Start with the analyzer in run mode.** Verify on the RS-232 terminal that the serial output stream from the analyzer is indicating operations in the "RUN" mode.
- **Reset the analyzer RS-232 serial input buffer:** Press the "enter" key once to reset the serial buffer. The analyzer will indicate that the serial buffer is empty by sending an asterisk character "\*". See example below:

```
...
RUN 20.9 % ALM1 ALM2 FLT 5,11
RUN 20.9 % ALM1 ALM2 FLT 5,11

*RUN 20.9 % ALM1 ALM2 FLT 5,11
RUN 20.9 % ALM1 ALM2 FLT 5,11
RUN 20.9 % ALM1 ALM2 FLT 5,11
...
```



- **Pause RS-232 serial output stream:** Carefully type the following command string: "sserfmt=0" and press "enter". The serial output stream should stop. If the serial output stream does not stop, reset the serial input buffer again and retype the command string. Also note that the input characters will be mixed in with the output characters on the RS-232 terminal. See example below

```
...
RUN 20.9 % ALM1 ALM2 FLT 5,11
RUN 20.9 % ALM1 ALM2 FLT 5,11
RUN 20.9 % ALM1 ALM2 FLT 5,11
sSERfRUN 20.9 % ALM1 ALM2 FLT 5,11
mtRUN 20.9 % ALM1 ALM2 FLT 5,11
=0
*
```

- **Change Alarm 1 Setting:** Type the following command string: "salmlset=X" and press "enter". "X" is a number between 0.0 and 1.0 denoting 0 to 25% oxygen concentration. For example, if the desired new setpoint for Alarm 1 is 5% oxygen, type "salmlset=0.05" and press "enter". If the change is successful, the analyzer will display another asterisk "\*" character. See example below for setting Alarm 1 to 1.5%:

```
*salmlset=0.015
*
```

- **Verify Alarm 1 Setting:** Type the following command string: "salmlset=X" and press "enter". The analyzer will display a number between 0.0 and 1.0 denoting 0 to 25% oxygen concentration. Verify that this number represents the desired Alarm 1 setting. See example below for setting Alarm 1 to 1.5%:

```
*?alm1set
0.015000000
*
```

- **Restart the RS-232 serial output stream:** Type "sSERfmt=1" to restart the RS-232 serial output stream. The analyzer will resume its timed serial output. See example below:

```
*sSERfmt=1
*RUN 20.9 % ALM1 ALM2 FLT 5,11
RUN 20.9 % ALM1 ALM2 FLT 5,11
RUN 20.9 % ALM1 ALM2 FLT 5,11
RUN 20.9 % ALM1 ALM2 FLT 5,11
RUN 20.9 % ALM1 ALM2 FLT 5,11
```

The steps for changing Alarm 2 level settings are similar except that the two required command strings are "salm2set=X" and "?alm2set".

## Appendix D: RS-232 Port

The RS-232 port may be used to send data to a host computer. There are four available formats that the Model 5124BE-N1-WO may send data to the host computer. The speed of the data transmission can vary from 300BPS to 38.4KBPS. Unless otherwise specified, the following is the default transmission format:

PROPERTIES	MODEL 5124BE-N1-WO ANALYZER SETTING
BITS PER SECOND	9600
DATA BITS	8
PARITY	None
STOP BITS	1
FLOW CONTROL	None
DATA FORMAT	HUMAN READABLE

The following are the available formats:

- **No Output:** The Model 5124BE-N1-WO analyzer does not send any data on the RS-232 port.
- **Human Readable:** The output data format is suitable for a data terminal that a person can read. The data stream includes the following: Mode • O<sub>2</sub> Concentration • Alarm-1 status • Alarm-1 status • list of Fault codes active.
- **Machine Code with No Checksum:** The data stream is formatted to be easily readable by another computer. No checksum is provided to ensure the data integrity. The data stream includes the following information: Start Transmit • O<sub>2</sub> Concentration • Fault codes active • List of Fault Codes • Alarm-1 status • Alarm-1 status • End Transmit. For detailed information on data formats, please contact the Neutronics Service Department.
- **Machine Code with Checksum:** The data stream is formatted to be easily readable by another computer. A 256-bit checksum is provided to ensure the data integrity. The data stream includes the following information: The order of data in each packet is as follows: Start Transmit • O<sub>2</sub> Concentration • Fault codes active • List of Fault Codes • Alarm-1 status • Alarm-2 status • Checksum • End Transmit. For detailed information on data formats, please contact the Neutronics Service Department.
- **Tab Delineated:** The format is similar to the Human Readable, but all the data is tab delineated to allow for easy transfer of data to a spreadsheet program.

**Setting Up RS-232 Terminal Interfacing using Microsoft Windows 95 or later:**

- **Open HyperTerminal.** On your PC computer, open HyperTerminal: Navigate from the Windows desktop - Select Start → Programs → Accessories → Communications → HyperTerminal.
- **Configure HyperTerminal.** In HyperTerminal, create and configure a new connection - follow the prompts:

PROMPT	YOU ENTER
CONNECTION NAME	5100E
CONNECT TO	COM1, or other available COM port

In HyperTerminal, select the correct COM port properties, to interface properly with the Model 5100E:

PROPERTIES	YOU ENTER
BITS PER SECOND	9600
DATA BITS	8
PARITY	None
STOP BITS	1
FLOW CONTROL	None
TERMINAL EMULATION	VT 100 *

\* Terminal Emulation may not be selectable with all operating systems.

Select "Apply" and "OK" as prompted. The Hyper Terminal program will immediately begin communicating with the Model 5100E, and the Model 5100E will commence sending data via ASCII code dump to the PC. The information from the analyzer will be sent in ASCII strings, at 1-second intervals. Data will be sent in the factory default "Human Readable" format unless another format is requested by the user.

## Appendix E: System Setup

The Model 5124BE-N1-WO is shipped ready to install and operate. It has been factory configured to meet the requirements of your application. The user, however, may change the settings from the setup menu accessed RS-232 terminal.



**WARNING:** Altering the system setup settings will alter the performance of the oxygen analyzer, and may affect its performance in your process. Neutronics is not responsible for any effects from this change in performance.

**WARNING:** Altering the system setup settings do not alter the factory default settings. If a Factory Restore function is performed, all settings will revert back to the ones programmed at factory. It is best to have all your required settings be programmed at the factory.

**IMPORTANT:** Before changing any of the Model 5124BE-N1-WO settings, refer to the software setup log that is supplied from the factory for reference. If the user has any questions before proceeding with changing analyzer settings, please contact the Neutronics Service Department for assistance.

## Accessing the System Setup Menu

To access the Setup Menu, press "enter" to reset the RS-232 serial input buffer. Then, type "setup" and press "enter". The following menu will appear on the RS-232 terminal:

```
*****> SETUP MAIN MENU <***** (U00)
Press To Change (F3-Exit Setup Mode Now)
- - - - -
  F  Return All Settings to the Factory Delivered Settings
 1 I  System Information
 2 R  Alarm Relay Setup
 3 A  Analog Output Setup
 4 G  Display Auto-Range Setup

 5 S  Serial (RS-232) Output Setup

 6 O  Operator Keypad Lockout Setup

 7 H  Sample and Hold Setup
 8 C  Check Sensor Alarm Setup
 9 Z  Assume Low End Calibration when concentration: 6-> 0.0 to 0.5 %

  T  Calibration Mode Auto Return to Run after 120.0 seconds

 0 L  220 Volt Line Voltage: No

 Q Esc Quit, return to the previous menu

  ->
```



**WARNING:** Do not alter any settings without consulting the factory first. Changing any of the settings will affect the performance of the analyzer. Neutronics is not responsible for any effects from this change in performance.

**NOTE:** To return all settings to factory default settings, type "F" for "Return All Settings to the Factory Delivered Settings".

### The following are the steps to disable System Fault 18 - low (Check Sensor):

Note: This procedure disables the unacceptably low oxygen sensor measurement only. Fault 18 will still occur if an unacceptably high measurement is measured. Use this procedure only if the sensor verification (Appendix A) passes, and Fault 18 occurs in the measurement of pure background gas. With Fault 18-low disabled, the analyzer can still detect some analyzer, cable and sensor problems.

- Type "8" or "C" for "Check Sensor Alarm Setup".
- The following prompt will appear: "Enable Check Sensor Alarm Below 5uV?"
- Type "N" to disable System Fault 18 - low, and press enter.
- Type function key "F3" to exit the System Setup menu.

## Appendix F - Spare Parts List

PART NUMBER	DESCRIPTION
5-06-4900-65-0	Operations Manual
C1-17-0052-00-0	Replacement terminal block - TB1
C1-17-0142-00-0	Replacement terminal block - TB2
C1-17-0112-00-0	Replacement terminal block - TB3
C7-01-5124-03-0	Model 5124BE-N1-WO Oxygen Analyzer
C6-01-1001-38-3	Sensor Interface Cable, 3 Meters
C6-02-4000-00-1	External Oxygen Sensor Assembly
1-11-0000-14-0	Ferrite Clamp

## Appendix G - MSDS Material Safety Data Sheet

### 1. Product Identification

Model 5124BE-N1-WO Analyzer with External Sensor furnished by  
Neutronics Inc. • 456 Creamery Way • Exton, PA USA, 19341 •  
Telephone: 610-524-8800.

---

### 2. Hazardous Ingredients of Solution

None.

---

### 3. Health Hazard

None.

---

### 4. Physical and Chemical Data

N/A.

---

### 5. Unusual Fire and Explosion Hazards

None, when operated as specified by the Installation Manual.

---

### 6. Health Hazard Data

None.

---

### 7. Emergency and First-Aid Procedures

N/A.

---

### 8. Handling

**Protective measures during cell replacement:**

N/A.

---

Note: The above data is based on MSDS provided by the manufacturers of components and by tests conducted by Neutronics. Neutronics believes that this information to be accurate and reliable. This information is supplied as reference only. Neutronics disclaims any liability for damage or injury which results from the use of the data and nothing contained therein shall constitute a guarantee, warranty, or merchantability or representation by Neutronics with respect to the data, the product described, or their use for any specific purpose, even if that purpose is known to Neutronics.

# Appendix H - Declaration of Conformity

## Appendix H - Declaration of Conformity

According to ISO Guide 22 and EN 45014,

**NEUTRONICS, INC.**  
**456 Creamery Way**  
**Exton, PA 19341**

declares that our product:

MODEL 5124BE-N1-WO Oxygen Analyzer System  
PART NUMBER: C7-01-5124-04-3

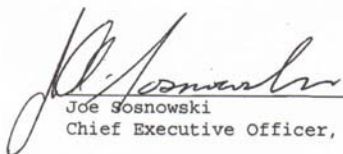
conforms to the relevant provisions of the following EC Council Directives:

LOW VOLTAGE DIRECTIVE 72/23/EEC:  
IEC 61010-1/EN 61010-1, Safety Requirements for Electrical Equipment for Measurement, Control and Laboratory Use

EMC DIRECTIVE 89/336/EEC:  
IEC 61326-1:2006, Electrical equipment for measurement, control and laboratory use EMC Requirements Part 1: General Requirements

This product herewith complies with the requirements of the Low-Voltage Directive 72/23/EEC and the EMC Directive 89/336/EEC and carries the CE-Marking accordingly.

Signed by Neutronics Inc.'s designated representative

 Date: 22 August 2008  
Joe Sosnowski  
Chief Executive Officer, Neutronics, Inc.

Manual Part Number: 5-06-4900-65-0    Revision Level: A    File Name: MN-A-0177    Page 48  
ECO 8541



## **Appendix I - Decommissioning the Model 5124BE-N1- WO Analyzer**

Concerning Neutronics' environmental compliance, in regards to producing new electrical equipment, the RoHS directive, 2002/95/EC, a European directive, requires manufacturers of certain types of electrical equipment, not to use materials that contain restricted quantities of "lead, mercury, cadmium, hexavalent chromium, polybrominated biphenyls (PBB) or polybrominated diphenyl ethers (PBDE)".

Measuring and monitoring equipment is not in the scope of the RoHS directive, and is therefore compliant. When decommissioning equipment, dispose of equipment in a manner that equipment produced before 13th August 2005, according to local codes.