



Neutronics
Gas Analysis Solutions

Instruction manual

Model 3-LPM-N1-SS

Remote Sensor Module and Positive Pressure
Sampling System
For use with Model 3100 Oxygen Analyzer

Trace to percent O₂ measurement
0.1 PPM to 100% range

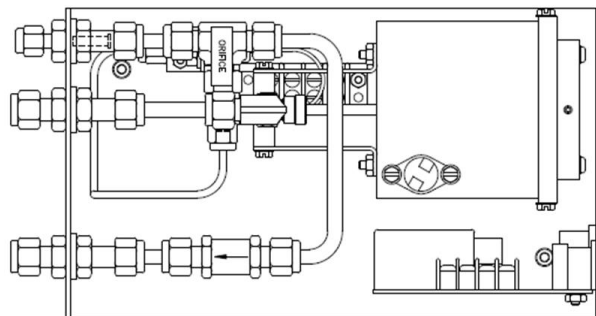

Manual file name: MN-A-0012
Manual part number: C5-06-4900-18-0
Revision Level: C
Revision date: January 4, 2017

Table of Contents

Welcome	iv
Notice	iv
Safety instructions.....	v
Designated use	v
Operational safety	v
1 Introduction.....	1
1.1 Functional overview	1
1.2 Features	1
1.3 System component overview	2
1.3.1 RSM electrical configuration	2
1.3.2 RSM pneumatic configuration	2
1.3.3 Oxygen sensor	3
1.3.4 Sensor heater.....	3
1.3.5 Heater modulator.....	3
1.3.6 Heater control board	3
1.3.7 Chassis.....	3
1.4 Oxygen sampling components.....	4
1.4.1 Sample filter	4
1.4.2 Sensor stream orifice	4
1.4.3 Bypass stream check-valve	4
1.5 Inputs and Outputs.....	4
1.5.1 Sample inlet port	4
1.5.2 Sample outlet port	4
1.5.3 Sample bypass port	5
1.5.4 VAC electrical power plug	5
1.5.5 Model 3100 analyzer interface	5
2 System installation and start-up.....	7
2.1 Installing the analyzer	7
2.1.1 Step 1 – Locate the remote sensor module (RSM).....	7
2.1.2 Step 2 – Install the Model 3100 analyzer	8
2.1.3 Step 3 – Install the Model 3-LPM-N1-SS RSM	8
2.1.4 Step 4 – Power up the RSM and analyzer module	11
3 Operation.....	12
3.1 Overview	12
3.2 Online sampling mode	12
3.3 Calibration sampling mode.....	12
3.3.1 Remove the RSM from online service	12
3.3.2 Apply calibration gas to the RSM	13
3.3.3 Return the RSM to online service	13

4	Maintenance and troubleshooting.....	14
4.1	Routine periodic maintenance.....	14
4.1.1	Calibrate the sensor	14
4.1.2	Clean the RSM chassis.....	14
4.1.3	Sensor clean	15
4.1.4	Replace the oxygen sensor.....	15
4.2	Troubleshooting.....	15
4.2.1	Fault codes.....	16
4.2.2	Troubleshooting Common Problems with the RSM.....	16
5	Appendices.....	18
5.1	Appendix A – Spare parts list.....	18
5.2	Appendix B – Specifications.....	18
6	Limited warranty.....	19

Welcome

The Model 3-LPM-N1-SS Remote Sensor Module (RSM) is the sampling system designed for use with the Model 3100 analyzer -- a compact microprocessor controlled instrument designed for oxygen measurement. This manual provides detailed information on how to operate and maintain the Model 3-LPM-N1-SS RSM from Neutronics.

For additional information regarding the maintenance and service of the Model 3-LPM-N1-SS RSM and Model 3100 analyzer, please contact the technical support team at Neutronics. If you have questions or comments, we would like to hear from you.

Neutronics Inc.
Gas Analysis Solutions
456 Creamery Way
Exton, PA 19341
Tel: +1-610-524-8800
Toll Free: 800-378-2287 (US only)
Fax: +1-610-524-8807
EMAIL: info@neutronicsinc.com

Equipment Serial Number: _____

Notice

Product improvements and enhancements are continuous; therefore, the specifications and information contained in this document are subject to change without notice.

Neutronics, Inc. shall not be liable for errors contained herein or for incidental or consequential damages in connection with the furnishing, performance, or use of this manual.

No part of this document may be photocopied, reproduced, or translated to another language without the prior written consent of Neutronics, Inc.

This work is protected under Title 17 of the US Code and is the sole property of Neutronics Inc. No part of this document may be copied or otherwise reproduced, or stored in any electronic information retrieval system, except as specifically permitted under US copyright law, without the prior written consent of Neutronics Inc.

Copyright ©2017 Neutronics Inc.

Safety instructions

WARNING

- ▶ Installation, operation, and maintenance of the unit must be performed by trained technical personnel.
- ▶ Technical personnel must be authorized to perform the tasks by the owner-operator.
- ▶ Electrical connections must be established by an electrical technician.
- ▶ To prevent personal injury, technical personnel must read, understand, and follow all warnings and instructions in this manual before attempting installation or operation of the unit.
- ▶ If the operator cannot read these instructions, operating instructions and safety precautions must be read and discussed in the operator's native language.
 - Si el operador no puede leer las instrucciones, las instrucciones de operación y las precauciones de seguridad deberán leerse y comentarse en el idioma nativo del operador.
 - Si l'utilisateur ne peut lire les instructions, les instructions et les consignes de sécurité doivent lui être expliquées dans sa langue maternelle.
- ▶ No operator access is permitted inside the housing. Repairs not described in the Operating Instructions may only be performed by the manufacturer or authorized service team.

Designated use

- ▶ The analyzer is a microprocessor-based instrument for oxygen measurement in clean gas applications. It is designed to minimize all effects of static discharges and interference from RFI and EMI emissions.
- ▶ If the equipment is used in a manner other than as described, the protection provided by the equipment may be impaired and may pose a threat to the safety of personnel.
- ▶ The manufacturer does not accept liability for damage caused by improper or non-designated use.

Operational safety

CAUTION

- ▶ Follow all local standards, safety regulations, and installation guidelines. Observe proper safety procedures when working with pressurized gases.
- ▶ Mount the unit in a manner that will guard against excessive vibration, collapse, and exposure to liquids, flammable gases, flames, or high temperatures.
- ▶ Mount the unit in an area of free airflow to prevent the enclosure from exceeding the operating temperature specifications. Do not mount the analyzer against hot surfaces. Do not block the ventilation openings on the analyzer enclosure.
- ▶ Do not expose the Model 3100 enclosure to water, high humidity or moisture. The analyzer enclosure is not watertight.
- ▶ Do not expose the Model 3-LPM-N1-SS to flame or high temperatures.
- ▶ Do not expose the Model 3-LPM-N1-SS to flammable gases or vapors. The unit is not rated explosion proof or intrinsically safe.
- ▶ Ensure that the pressure of gas entering the remote sensor module (RSM) is compatible with the operating instruction. Do not exceed 20 PSIG.
- ▶ Do not expose the unit directly to an unregulated gas supply. High gas pressures may cause a failure in the sampling system.
- ▶ The unit operating voltage is: 110 or 208 VAC $\pm 10\%$, 50/60Hz, 3.5A, single phase, 3-wire. Failure to use the proper operating power may result in damage to the unit.
- ▶ The power cord is the disconnecting device. Do not position the equipment so that it is difficult to remove the power.
- ▶ Prior to commissioning, check that all connections are correct. Calibrate the unit at an equivalent pressure and flow rate to the measured gas before use.

1 Introduction

1.1 Functional overview

The Neutronics Model 3-LPM-N1-SS is a remote sensor module and process sampling system designed for use with the Neutronics Model 3100 trace to percent oxygen analyzer. The Remote Sensor Module (RSM) is part of a high quality and efficiently designed solution for gaseous oxygen measurement and control applications.

The Model 3-LPM-N1-SS serves as both the receptacle for the oxygen sensor and the delivery system for process gas samples under positive pressure. Gas is pumped in a continuous flow from the RSM sample inlet port, through the sampling system to the oxygen sensor, and then out through the RSM sample exhaust port. The sensor determines the oxygen concentration of the gas and reports the measurements to the Model 3100 oxygen analyzer in real-time.

The RSM (see Figure 1) features the Neutronics rapid-response zirconium oxide (ZR100) sensor, designed for measuring parts-per-million (PPM) to percent range oxygen. It is a solid-state device based on a zirconium oxide solid ceramic electrolyte sensor. The ZR100 sensor is responsive to changes in the partial pressure of oxygen of a sampled gas in the range from 0.1 PPM to 100% concentration of O₂. It has an indefinite storage life.

Model 3-LPM-N1-SS remote sensor module (RSM)



Model 3100 analyzer

Fig. 1, RSM with Model 3100 analyzer module

1.2 Features

The Model 3-LPM-N1-SS RSM is designed to be surface mounted on an equipment or process control panel. Because of the compact design of the RSM, it can be integrated into a variety of systems or components, and it can be mounted close to the sampling point to ensure the optimal response time for process control applications.

Other key features include:

- Ultra-fast response time
- Not position or motion sensitive
- Not affected by Oxygen Shock: can be exposed to air and measure PPM oxygen in seconds
- Small compact packaging
- Top or bottom mounting
- 316 SS wetted parts

1.3 System component overview

1.3.1 RSM electrical configuration

The schematic for the RSM electrical configuration is shown in Figure 2.

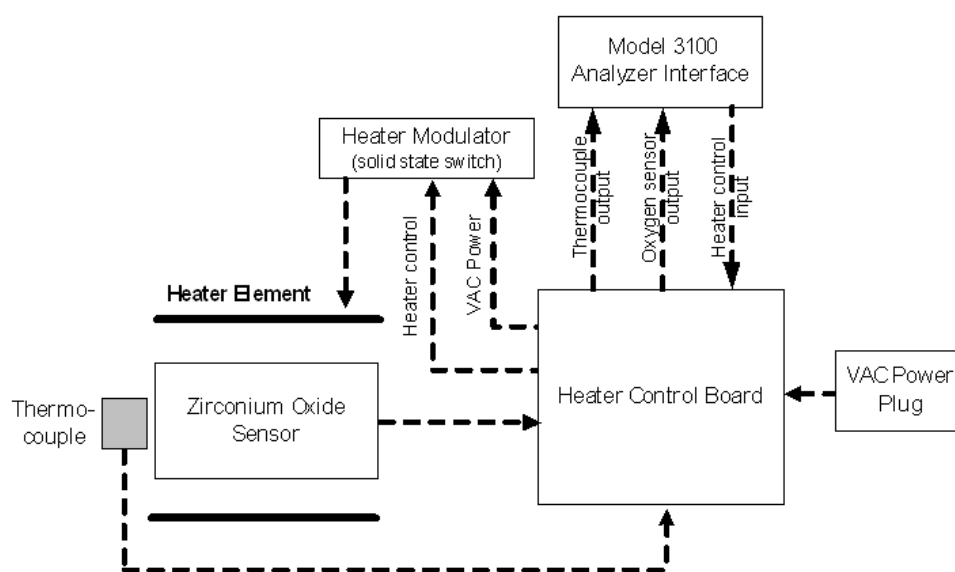

Fig. 2, RSM electrical configuration

1.3.2 RSM pneumatic configuration

The schematic for the RSM pneumatic configuration is shown in Figure 3.

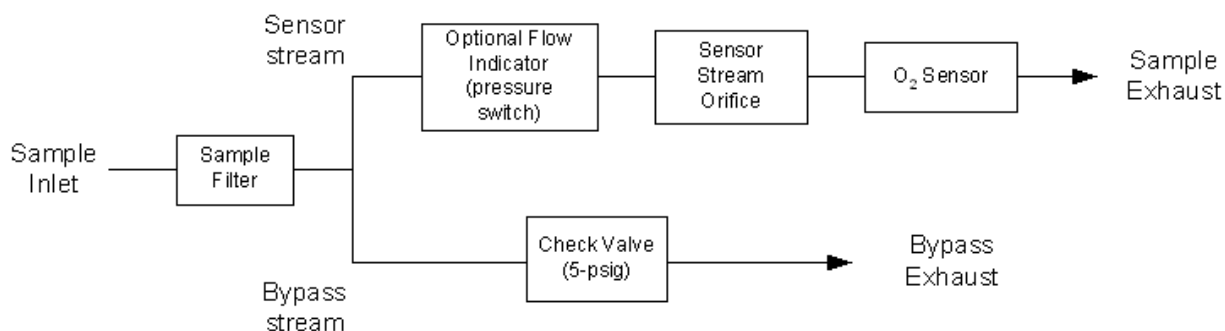

Fig. 3, RSM pneumatic configuration

1.3.3 Oxygen sensor

The Neutronics rapid-response zirconium oxide (ZR100) sensor is a solid-state ceramic device. When heated to an elevated temperature by its unique furnace, it produces a predictable electrical output in response to changes in the partial pressure of oxygen of a sampled gas (in the range from 0.1 PPM to 100% concentration). The most notable advantage of the ceramic sensor technology is its ability to rapidly measure oxygen through large step changes in concentration. The ZR100 sensor can accurately measure PPM concentrations of oxygen within seconds after exposure to air.

The sensor is constructed of a specially formulated porous zirconium oxide electrolyte tube. The tube surface is coated with a layer of porous platinum on the inside and outside. Each coated surface serves as an electrode – one as a cathode and the other as an anode. A unique heater assembly and thermocouple probe provide a controlled temperature environment for sensor operation.

At operating temperature, openings within the ceramic tube lattice allow oxygen ions to pass. If the partial pressure of oxygen is equal on both sides of the ceramic lattice, then there is no net flow of ions between the electrodes (for example – the sample gas and reference gas are both air). However, when the partial pressure of oxygen of the sample gas is different from the reference gas, there is predictable ionic transfer.

At operational temperature, oxygen is electrochemically reduced at the cathode. Oxygen ions migrate through the ceramic electrolyte and are electrochemically oxidized at the anode. As a result, an equal amount of oxygen is produced at the anode at the same time oxygen is reduced at the cathode. The voltage produced is proportional to the net difference in the partial pressures of oxygen in the reference gas (air at 20.9% oxygen) versus the sampled gas.

1.3.4 Sensor heater

The sensor heater maintains the normal operating temperature of the oxygen sensor for proper operation. The sensor heater is housed in an aluminum chassis that is filled with insulating material designed to prevent heat loss. The heater assembly includes a thermocouple (see section 1.5.5.2). The Model 3100 analyzer uses the thermocouple output to generate the heater control input to the RSM (see section 1.5.5.3) for regulating the sensor heater's operating temperature. The sensor heater requires a modulated 110/208 VAC, 50/60 Hz power source. A thermal cutout switch is included, to prevent over-temperatures from damaging the assembly.

1.3.5 Heater modulator

The heater modulator is a high-speed solid-state switch mounted on the heater control board (section 1.3.6) that provides precision control of the sensor heater temperature by modulating its VAC electrical power input continuously. Its duty-cycle is determined by the frequency of the heater control input from the Model 3100 analyzer.

1.3.6 Heater control board

The heater control board serves as the main interface between the RSM and the Model 3100 analyzer (see Figure 2). It houses the Model 3100 analyzer interface port (see section 1.5.4) and the VAC electrical power plug for the RSM (see section 1.5.5). The oxygen sensor output, the heater thermocouple output, and the heater control input are all interfaced with the Model 3100 analyzer through the heater control board. In addition, it houses the heater modulator.

1.3.7 Chassis

The chassis is manufactured of anodized black aluminum sheet metal. The chassis serves as the main frame to hold the sensor in place inside the sensor heater and to support the sample gas tubing, the high

purity sample pump, and the electrical interface hardware. It also protects the sensor from dust and external heat sources. There are louvers on each side and on top of the chassis for airflow, to prevent build-up of excess heat in the RSM from the sensor heater.

1.4 Oxygen sampling components

The Model 3-LPM-N1-SS RSM uses flow and pressure reduction to control and stabilize process gas flow from a pressurized source for oxygen measurement (see Figure 3). From a single inlet source, the sample stream separates into two parallel streams – a "sensor" stream, and a "bypass" stream. The sensor stream is controlled to a reduced flow, directed to the sensor, and then exhausted. The balance of flow through the RSM is shunted to the bypass stream, and then exhausted. The two exhaust destinations are discrete.

The two-stream configuration provides a higher total gas flow for faster pneumatic response in process control applications and ensures that the ZR100 sensor has a stable sample flow for accurate measurement.

1.4.1 Sample filter

Designed to filter out particulates entrained in the sample gas, an in-line 40-micron sintered stainless steel filter is included in the RSM at the sample inlet (see Figure 3). If the filter becomes clogged during normal use, contact the Neutronics factory for replacement instructions.

1.4.2 Sensor stream orifice

An orifice-plate is included in the sensor stream of the RSM sampling system to reduce and stabilize sample flow (see Figure 3). The orifice maintains a reduced constant flow of sample gas from the measured process to the oxygen sensor. If the orifice becomes clogged during normal use, contact the Neutronics service department. Do not return the RSM to normal service with the sensor stream orifice-plate removed.

1.4.3 Bypass stream check-valve

A check-valve designed to open at 5-PSIG of pressure is included in the RSM sampling system (see Figure 3). If the sampled source pressure exceeds 5-PSIG, the surplus sample gas will be shunted around the sensor stream. This will help to maintain a stable sample flow to the oxygen sensor and to protect it from over-pressure conditions.

1.5 Inputs and Outputs

1.5.1 Sample inlet port

The sample inlet port is a 1/8" tube compression bulkhead fitting in the RSM chassis for pneumatic interfacing with the measured process (see Figure 4). It is the single sample gas inlet to the RSM.

1.5.2 Sample outlet port

The sample outlet port is a 1/4" tube compression bulkhead fitting in the RSM chassis (see Figure 4). It is the low volume exhaust line, supplied by the flow-controlled sensor stream in the RSM. It should be connected to a suitable vent location.

1.5.3 Sample bypass port

The sample outlet port is a 1/4" tube compression bulkhead fitting in the RSM chassis (see Figure 4). It is the high volume exhaust line, supplied by the bypass stream in the RSM. It should be connected to a suitable vent location.

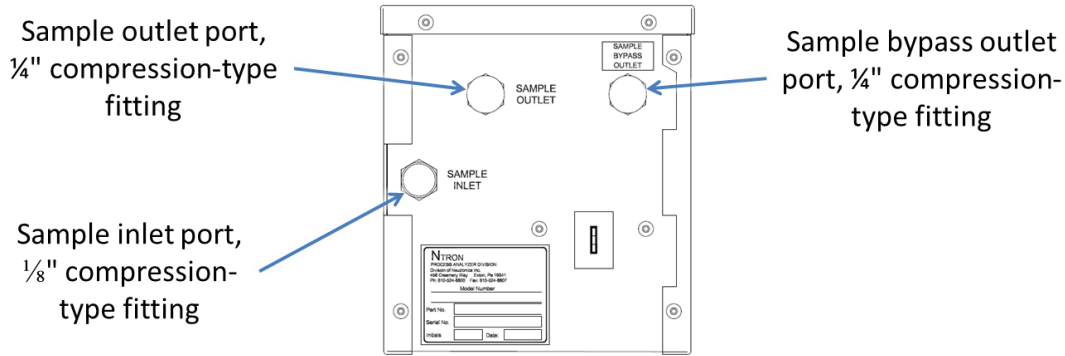

Fig. 4, Front view

1.5.4 VAC electrical power plug

The Model 3-LPM-N1-SS requires VAC electrical power. The VAC electrical power cable connector is a standard 3-prong grounded male connector, IEC 60320-1 C14 style (see Figure 5).

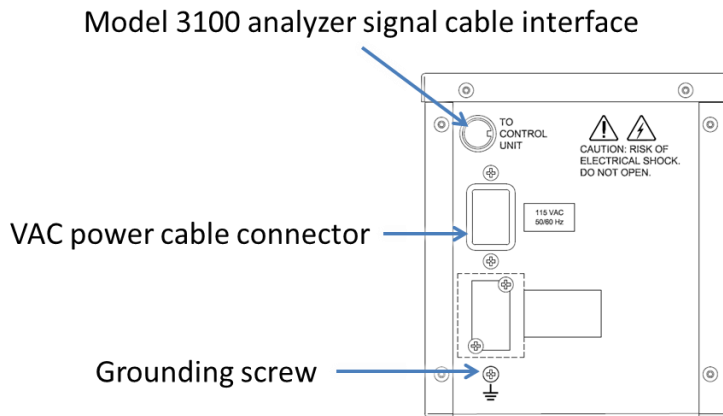

Fig. 5, Rear view

1.5.5 Model 3100 analyzer interface

The Model 3100 analyzer interface is a single 8-pin DIN connection that connects the RSM electrically to the Model 3100 analyzer. It includes the oxygen sensor output, the sensor heater thermocouple output, and the sensor heater control Input. An interface cable is included with the Model 3100/RSM system.

1.5.5.1 Oxygen sensor output

The oxygen sensor output is used by the Model 3100 analyzer to indicate the oxygen concentration in the measured process. It is proportional to the sampled oxygen present in the process gas stream or vessel headspace.

1.5.5.2 Sensor heater thermocouple output

The thermocouple included on the heater assembly feeds back a voltage potential to the Model 3100 analyzer proportional to the sensor heater temperature through the sensor heater thermocouple output. The Model 3100 uses that electrical output to control the sensor heater temperature.

1.5.5.3 Sensor heater control input

The Model 3100 generates a variable frequency control signal to the RSM sensor heater control input for the heater modulator, based on the RSM sensor thermocouple output. The heater control input from the Model 3100 analyzer determines the duty-cycle of the heater modulator to keep the sensor heater at the normal operating temperature by changing its average VAC input power. This method provides continuous control of the sensor heater temperature within the limited control range necessary to operate the solid-state oxygen sensor.

2 System installation and start-up

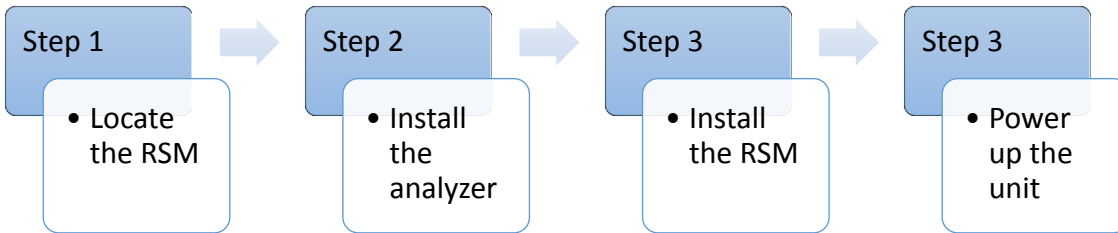

Fig. 6, Installation and start-up

2.1 Installing the analyzer

2.1.1 Step 1 – Locate the remote sensor module (RSM)

The Model 3-LPM-N1-SS RSM designed to be surface mounted on an equipment or process control panel. Select a suitable location for the RSM based on the following:

- ▶ The distance to the gas sample pickup point is as short in length as possible
- ▶ The plumbing to the sensor is located where it is easy to install and maintain
- ▶ There is clearance to allow easy access to the interface cable connection
- ▶ There is clearance to allow easy access to the sample input and output connections
- ▶ There is easy and ample space for installation of the VAC power cable connection on the rear of the analyzer chassis
- ▶ There is free airflow to prevent the chassis from exceeding the operating temperature specifications (maximum ambient temperature of 40° C)
- ▶ There are no adjacent hot surfaces
- ▶ No adjacent surface will block the ventilation louvers

Installation of the RSM chassis requires four (4) clearance holes for the #8-32 threaded screws. See Figure 7 for the bolt hole pattern (dimensions are shown in inches).

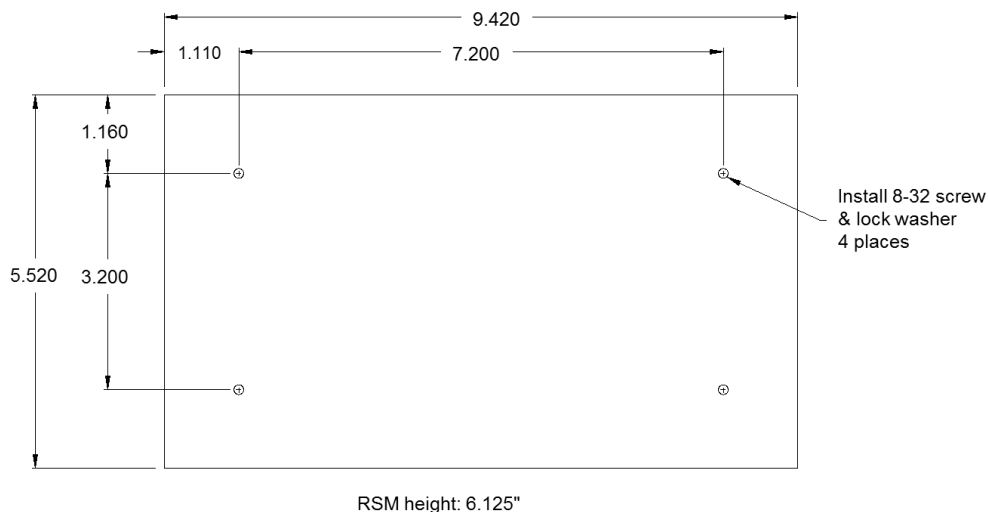

Fig. 7, RSM bolt hole pattern (bottom view)

2.1.2 Step 2 – Install the Model 3100 analyzer

For detailed installation instructions for the Model 3100 analyzer (when installed separately), please refer to the separate instruction manual MN-A-0005.

2.1.3 Step 3 – Install the Model 3-LPM-N1-SS RSM

CAUTION Remember to verify the proper operating voltage (see section 4.1.2.17) – 110 or 208 VAC. Failure to use the correct voltage will result in damage to the RSM components.

- ▶ Electrical connections on the rear of the Model 3100 oxygen analyzer or at the RSM may have hazardous voltages present once power has been applied to the unit. High voltages may remain for a short time even after power has been disconnected from the two units. Take care in observing standard electrical practices when making electrical connections to the Model 3100 oxygen analyzer and RSM.
- ▶ The model 3-LPM-N1-SS RSM is not rated intrinsically safe or explosion proof. Be certain that no flammable and toxic gases are present in the area where the RSM will be installed.

CAUTION The Model 3-LPM-N1-SS chassis is not rated waterproof. Do not mount the RSM in an area where it may contact water or other liquid elements.

WARNING Be certain that all power is OFF to the analyzer and associated wiring (cables) before attempting installation. DO NOT WORK WITH LIVE WIRES! Do not leave any exposed wire at the terminal blocks. Before applying power, ensure terminal blocks are fully inserted into the mating connector at the analyzer.

CAUTION Be certain to regulate the supplied gas pressure to the 3-LPM-N1-SS sample inlet port. Never connect an unregulated gas supply to the RSM. Pressure requirements: 6 to 20 psig (constant).

WARNING Do not allow the 3-LPM-N1-SS to sample Hydrogen, Carbon Monoxide, or any Hydrocarbon gases while in service. Do not mount the 3-LPM-N1-SS in an area where Hydrogen, Carbon Monoxide, Hydrogen Disulphide, Hydrocarbon, or Halogenated gases may be present around the unit while in service. If the O₂ sensor is exposed to any of these gases, system accuracy will be affected.

- ▶ The model 3-LPM-N1-SS must be mounted in an area where there is free air flow, providing a constant source of ambient air around the unit, containing 20.9% oxygen. Higher or lower levels of oxygen concentration in the atmosphere around the RSM will affect system accuracy.
- ▶ Do not subject the model 3-LP-N1-SS to mechanical impact, continuous mechanical vibration, or electrical shock.

Mount the Model 3-LPM-N1-SS on a flat surface. Follow the bolt hole pattern on the mounting plate (see Figure 7).

2.1.3.1 Sample inlet port

Connect the sample gas inlet tubing from the process to the $\frac{1}{8}$ " compression bulkhead fitting marked "SAMPLE INLET" (see Figure 4).

- ▶ Use 316-stainless steel tubing and $\frac{1}{8}$ " compression-type high purity fittings.
- ▶ Ensure that no grease, particulate, or solvent is present in the tubing during installation.
- ▶ Locate the sample inlet tubing connection on the chassis (see Figure 4).
- ▶ Fix all sample tubing and connectors.

A fixed calibration port may be implemented in the process sampling line by installing a stainless steel 3-way high purity manual ball valve into the sampling line (see Figure 8). Use 316-stainless steel tubing and $\frac{1}{8}$ " compression-type high purity fittings. Ensure that no grease, particulate, or solvent is present in the tubing during installation. Fix all sample tubing and connectors.

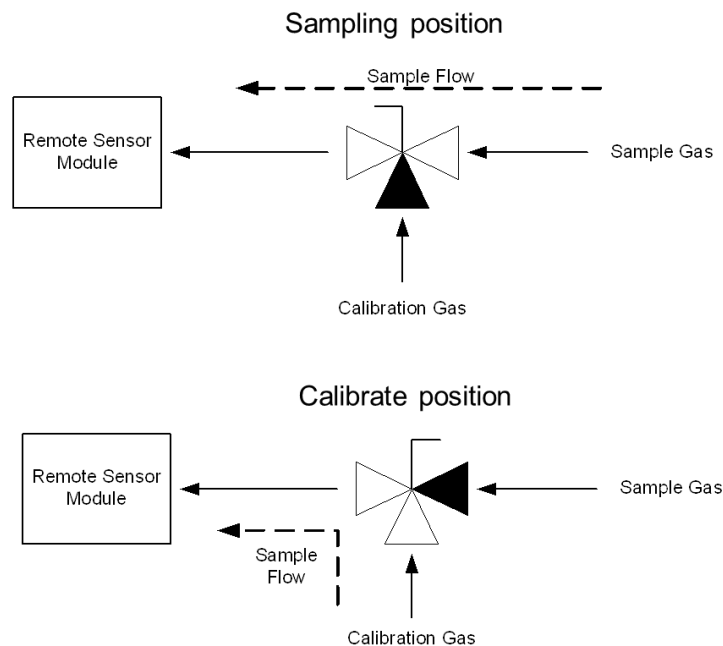

Fig. 8, Calibration gas fixture configuration

2.1.3.2 Sample outlet port

Connect the sample gas outlet tubing to the $\frac{1}{4}$ " compression bulkhead fitting marked "SAMPLE OUTLET" (see Figure 4).

- ▶ Use 316-stainless steel tubing and $\frac{1}{4}$ " compression-type high purity fittings.
- ▶ Select a vent location operating at atmospheric pressure or slightly negative for best results.

- ▶ Use a minimum of 2-meters of tubing to prevent back-flow of vent gas to the sensor.
- ▶ Ensure that no grease, particulate, or solvent is present in the tubing during installation.
- ▶ Locate the sample outlet tubing connection on the chassis (see Figure 4).
- ▶ Fix all sample tubing and connectors.

2.1.3.3 Sample bypass port

Pneumatic connection to a suitable bypass stream vent location is made at the ¼" compression bulkhead fitting on the rear of the RSM chassis, marked "SAMPLE BYPASS OUTLET".

- ▶ Use 316-stainless steel tubing and ¼" compression-type high purity fittings.
- ▶ Select a vent location operating at atmospheric pressure or slightly negative for best results.
- ▶ Use a minimum of 2-meters of tubing to prevent back-flow of vent gas to the sensor.
- ▶ Ensure that no grease, particulate, or solvent is present in the tubing during installation.
- ▶ Locate the sample outlet tubing connection on the chassis (see Figure 4).
- ▶ Fix all sample tubing and connectors.

2.1.3.4 Model 3100 analyzer interface

The electrical connection to the Model 3100 oxygen analyzer is made at the female 8-pin DIN connector on RSM chassis, marked "Signal 1". To connect the two units, use the interface cable supplied with the analyzer/RSM system. Match the cable connector with the ID label on the RSM chassis. Fix all wiring and connectors.

2.1.3.5 VAC electrical power plug

Electrical connections for VAC power are made at VAC power plug on the RSM chassis, marked "Line". To connect mains power to the RSM, use 16-AWG, 3-conductor, stranded-wire, insulated cable, terminated on one end with a female IEC connector. Supply single-phase 110/208 VAC, 50/60Hz, 30-Watts to the unit. Ground the connection at the source. Match the plug-in receptacle with the ID label on the RSM chassis. Fix all wiring and connectors.

2.1.3.6 Forced ventilation port

An optional ventilation port cut-out may be included on the RSM. It is used for special installations – where dust particle control is required or where cabinet space limitations or ambient temperatures surrounding the RSM could inhibit proper operation of the sensor (or damage system components).

2.1.3.7 Clean-room installation

For clean-room applications, the forced ventilation port on the RSM chassis can be connected to a vacuum source to create a flow of surrounding ambient air through the chassis louvers into the RSM module. This flow configuration will create a negative pressure potential at the RSM chassis exterior to prevent any particles from escaping from the unit into the surrounding clean-room environment.

Use a vacuum source of 0.5" to 5" water column gage to create 0.1 to 1.0 LPM airflow through the RSM. Connect the vacuum exhaust to a suitable vent location that will not create backpressure. Install a 1/4" compression bulkhead fitting on the rear of the RSM chassis, in the cut-out marked "Ventilation".

Connect the installed bulkhead fitting to the vacuum source using 316-stainless steel tubing, and 1/4" compression-type fittings. Ensure that no grease, particulate, or solvent is present in the tubing during installation. Match the forced ventilation output tubing connection against the ID label on the RSM chassis. Fix all tubing and connectors.

2.1.3.8 Elevated ambient temperature installation

For elevated ambient temperature installations, the forced ventilation output bulkhead fitting can be connected to a positive pressure clean dry air source to create a flow of air through the chassis louvers. This flow configuration will cause excess heat from the RSM to be carried away to assure proper sensor operation, and prevent damage to the RSM components for installations where there are elevated temperatures, and/or limited natural ventilation.

Use an Instrument grade (dew-point < 15° F, particulate size < 3 micron, hydrocarbon content < 1 PPM) positive pressure air source, regulated to create a 1-LPM flow of air through the RSM module. Install a ¼" compression bulkhead fitting on the RSM chassis, in the cut-out marked "Ventilation". No outlet vent connection from the RSM is required. Forced air will vent to ambient air through the RSM chassis louvers.

Connect the installed bulkhead fitting to the clean dry air source using 316-stainless steel tubing, and ¼" compression-type fittings. Ensure that no grease, particulate, or solvent is present in the tubing during installation. Match the forced ventilation port tubing connection against the ID label on the RSM chassis. Fix all tubing and connectors.

2.1.3.9 Pressure switch interface port (flow indicator)

The optional flow indicator is a voltage-free SPDT Pressure Switch that changes state when flow drops below 3-PSIG in the bypass stream of the RSM sampling system. The switch may be used like a control system field input, or it may be used as a direct mechanical interlock (see appendix B for voltage and current specifications). The user may choose fail-safe or non-fail-safe operation by connecting to the normally closed or normally open terminations respectively. The "normal" switch position is that state of the switch when gas flow through the RSM sampling system is above 3-PSIG.

Electrical connection from the flow indicator interface to the user control system is made at the female 3-pin DIN connector on the rear of the RSM chassis, marked "Flow Switch". To connect the flow indicator interface to user equipment, use the 15-foot interface cable supplied with the 3100-analyzer/RSM system. With the supplied cable, match the 3-pin male DIN connector with the ID label on the RSM chassis. Use the 18-22 AWG tab crimp terminations on the cable's opposite end to connect to the user auxiliary equipment. Match the color-coded wires: RED – Normally Open | RED/WHITE – Normally Closed | WHITE – Common. Fix all wiring and connectors.

2.1.4 Step 4 – Power up the RSM and analyzer module

After all connections are made to the RSM and the Model 3100 analyzer module, the RSM will not require direct operational interface. All user-interfacing for system configuration, operation, and maintenance is performed via the Model 3100 analyzer. For detailed instructions on the Model 3100 oxygen analyzer, please refer to the separate instruction manual (MN-A-0005).

The Model 3-LPM-N1-SS RSM and Model 3100 analyzer should now be ready for commissioning. Neutronics offers commissioning and Factory Acceptance Testing services by our factory certified technicians. Please contact one of our service technicians to schedule a service call

3 Operation

3.1 Overview

The Model 3-LPM-N1-SS RSM is a modular component of the Model 3100 oxygen analyzer system with no direct user operational interface. When installed, the RSM interfaces with the Model 3100 analyzer continuously to perform its functions of gaseous oxygen sampling and measurement. The RSM “modes” indicate the sources of sample gas that the unit collects and measures.

There are two modes of RSM operation referred to in this document – online sampling and calibration sampling. Online sampling is for monitoring the oxygen concentration in a process gas stream or vessel headspace under normal system conditions. Calibration sampling is for sensor calibration and system maintenance.

3.2 Online sampling mode

Online sampling is applicable during all Model 3100 analyzer system modes – Self-test & warm-up, Run, Alarm-1 active, Alarm-2 active, and Fault active (see the Model 3100 analyzer instruction manual, MN-A-0005). During normal system operation, the Model 3-LPM-N1-SS RSM should remain connected to the measured process and to a suitable gas vent location (see section 2.3 in this manual). To prevent premature wear of tube-ends and fittings, connections should not be removed or opened except in the case of system calibration or maintenance. Worn sampling system components could cause gas leakage, leading to skewed oxygen readings and/or hazardous environmental conditions.

The measured process may be shut down or taken off-line without purging the sampling lines with inert gas or isolating the sampling system. The Model 3-LPM-N1-SS oxygen sensor will not be temporarily or permanently harmed by exposure to any oxygen level. It will respond to changes in concentration from ambient or enriched to trace levels within specifications (see Appendix D).

The sampling system should be isolated with blocking valves during any cleaning of the measured process if elevated temperatures, steam, and/or solvents are used during the cleaning process. If solvent is used, the sampling lines should be completely clear of any residue or solvent vapors before returning the system to online service

3.3 Calibration sampling mode

The RSM requires removal from online service prior to sensor calibration. Refer to the Model 3100 instruction manual section 3.2.1 for system calibration procedures. The user may introduce calibration gas to the RSM by disconnecting the sample inlet from the measured process and connecting a bottled calibration gas directly or by routing calibration gas to the sample inlet through a fixed gas manifold (see section 2.3.1). The second method will help prevent premature wear of tube-ends and fittings and increase long-term sampling system integrity.

3.3.1 Remove the RSM from online service

The RSM requires removal from online service to perform calibration. Calibration or other maintenance of the RSM should be performed when the measured process is not operating.



WARNING Before opening any part of the sampling system to air, make sure that the sampling lines are not pressurized and clear of any gas that may create a personnel or environmental hazard.

Disconnect the measured process from the RSM by completely removing the installed $\frac{1}{8}$ " compression-type high purity fitting from the bulkhead fitting on the RSM chassis (marked "INLET").

Most applications do not require opening or removing the exhaust connection. If however it is necessary to exhaust to an alternate path during calibration, completely remove the installed $\frac{1}{4}$ " compression-type high purity fittings from the bulkhead fitting on the RSM chassis, marked "SAMPLE OUTLET" and "SAMPLE BYPASS."

When connecting the RSM to alternate exhaust locations, use 316-stainless steel tubing, and $\frac{1}{4}$ " compression-type high purity fittings. Select a vent location that is known to be at atmospheric pressure at all times. Use a minimum of 2-meters of tubing to prevent back-flow of vent gas to the sensor. Ensure that no grease, particulate, or solvent is present in the tubing during installation. Match the sample outlet tubing connection to the ID label on the RSM chassis – "SAMPLE OUTLET" and "SAMPLE BYPASS OUTLET."

3.3.2 Apply calibration gas to the RSM

Use Certified Standard Grade bottled gas for calibration (see Model 3100 analyzer instruction manual section 3.2.1). When calibrating to ambient oxygen concentration, Instrument Grade compressed air may be used (Dew-point < 35° C, particulates < 3-micron, condensable hydrocarbons < 1-part-per-million).

Connection to a calibration gas source is made at the male $\frac{1}{4}$ " VCR or $\frac{1}{8}$ " compression bulkhead fitting on the RSM chassis, marked "Inlet". Use 316-stainless steel tubing, and high purity fittings. Ensure that no grease, particulate, or solvent is present in the tubing during installation. Match the sample inlet tubing connection to the ID label on the RSM chassis.

When connections are secure, apply gas to the system. Regulate the calibration gas pressure to match the pressure of the in-service sample gas, within the RSM pressure specification of 6 to 20 PSIG. Refer to the Model 3100 instruction manual for calibration procedures.



WARNING Never apply an unregulated gas supply to the RSM. High or uncontrolled pressures may damage the oxygen sensor, and/or sampling system components.

3.3.3 Return the RSM to online service

When calibration procedures are completed, the RSM is ready to return to service. Disconnect the calibration gas from the RSM by completely removing the installed high purity fitting from the fitting on the RSM chassis, marked "SAMPLE INLET". Reconnect the sample inlet port to the process for in-service oxygen measurement (see section 2.1.3.1).

4 Maintenance and troubleshooting

4.1 Routine periodic maintenance

Maintenance for the Model 3-LPM-N1-SS Oxygen analyzer is very simple. Apart from the normal maintenance for any instrument, such as cleaning the chassis and vacuuming internal components, the Model 3-LPM-N1-SS does not require any major periodic servicing. Calibration of the sensor on a known gas source should be performed on a regular basis (Refer to the Model 3100 instruction manual). The chart below should serve as a general guide for maintenance personnel (see Figure 9).

Task	Frequency		
	At commissioning	Annually	As required
Calibrate the sensor	✓		✓
Clean the chassis, vacuum internal components, and make sure the ventilation openings are unobstructed.		✓	✓
Replace the oxygen sensor (factory only)			✓ Sensor life expectancy 5 – 7 years

Fig. 9, Maintenance schedule

4.1.1 Calibrate the sensor

Refer to the calibration procedures in the Model 3100 equipment manual (see section 3.2.1) and in this manual (section 3.3).

4.1.2 Clean the RSM chassis

4.1.2.1 Tools required

- ▶ 2-ea. $\frac{3}{4}$ " open-end wrenches
- ▶ $\frac{5}{64}$ " button head screwdriver
- ▶ vacuum cleaner with small soft brush and thin nozzle attachments
- ▶ small clean acid brush

4.1.2.2 Cleaning procedure

- ▶ Remove the RSM from online service (see section 3.3.1). Unplug the RSM power cord. Disconnect the Model 3100 analyzer interface connection.

- ▶ Observe all lock-out/tag-out procedures. Hazardous voltages are present inside the chassis of the RSM. Do not remove any of the RSM chassis plates before removing mains power and the model 3100 interface connector from the unit.
- ▶ Wait 30 to 60-minutes for the sensor heater to cool before removing any of the RSM chassis plates. The sensor heater assembly cover is hot to the touch during normal operation.
- ▶ Using the vacuum cleaner and soft brush attachment, vacuum the exterior of the RSM chassis. Make sure that all louvers and vents are clear. Remove the top and side RSM chassis plates by removing the 18 button head machine screws from the unit. Set aside. Using the vacuum cleaner and soft brush attachment, vacuum the interior of the removed RSM chassis plates. Make sure that all louvers and vents are clear.
- ▶ Using the vacuum cleaner and soft brush attachment, vacuum the interior components of the RSM assembly. Use the thin nozzle attachment, or small acid brush to reach places that cannot be reached with the soft brush vacuum attachment. Be careful not to damage internal wiring, terminal or soldered wire connections, oxygen sensor, or any other delicate components in the RSM.
- ▶ Reassemble the RSM chassis and return to on-line service.

4.1.3 Sensor clean

The presence of certain gases will cause a build-up of chemical deposits on the sensor electrodes, temporarily blinding the sensor or skewing its electrochemical zero-reference point. Sensor clean mode is to be used if the ZR100 sensor is exposed to gases that may be affecting its ability to measure oxygen accurately or respond to significant step changes in oxygen concentration within specifications.

4.1.3.1 Tools required

- ▶ 2-ea. 3/4" open-end wrenches
- ▶ Maintenance gas – Instrument Grade compressed or bottled air

4.1.3.2 Cleaning procedure

- ▶ Remove the RSM from on-line service, and apply Nitrogen or Instrument Grade compressed air (see section 3.3). Allow the applied gas to sweep through the sampling system for a minimum 5 minutes to clear the sampling lines of gases potentially harmful to the oxygen sensor. From the Model 3100 analyzer, initiate the sensor clean routine (Refer to the Model 3100 instruction manual).
- ▶ When sensor clean is complete, perform system calibration and validate the reading to a known test gas concentration (see section 4.2.2.1). Re-calibrate if necessary and return the RSM to on-line service.

4.1.4 Replace the oxygen sensor

Model 3-LPM-N1-SS oxygen sensor (ZR100) replacement must be performed by a certified Neutronics factory repair technician. Please contact the factory service team for support.

4.2 Troubleshooting

The Model 3-LPM-N1-SS remote sensor module is a modular component of the Model 3100 oxygen analyzer system that has no direct user operational interface. When trouble occurs during normal operation of the Model 3100/RSM system, the Model 3100 offers several tools to aid in isolating the cause(s) of given symptoms.

As a starting point, the user may use the Model 3100 front panel to enter into "View Active Faults" mode. The user may also view active faults and other useful information via the Model 3100 RS-232 Service Port. The Model 3100 analyzer instruction manual includes procedures for viewing system faults. In addition, it includes descriptions of faults with possible causes.

4.2.1 Fault codes

Fault codes 1, 4, 15, and 16 apply to RSM components and peripheral equipment directly. The sensor output signal, the sensor output connection, and the heater temperature are monitored in real-time by the Model 3100, and faults are reported as they occur if readings fall outside of specified tolerances.

4.2.1.1 Fault Code 1 – Oven or sensor warming-up

The “Oven or sensor warming-up” fault indicates that the oxygen sensor is warming-up after a fresh power-up. The purpose of the alarm is to provide a control output to indicate that the sensor has not yet reached its operating temperature and that the Model 3100 is not yet ready for in-service oxygen measurement. When the sensor reaches its operating temperature the fault clears, and the analyzer enters normal system operation as per its setup parameters. If the system is unexpectedly aborting RUN mode during normal operation and fault code 1 appears, it may indicate that mains power to the RSM or Model 3100 analyzer is being interrupted.

4.2.1.2 Fault Code 4 – Clean mode is active

The “Clean mode is active” mode indicates that the user has entered the sensor clean mode from the Model 3100 analyzer control panel. This parameter allows the user to enable a sensor self-cleaning cycle if the oxygen sensor has been exposed to chemicals or gases that could affect its performance. During sensor clean mode, the 7-segment alphanumeric display will alternately show “CLE” and the temperature of the sensor heater in degrees centigrade.

4.2.1.3 Fault Code 15 – Bad user calibration

The “bad user calibration” fault indicates that the user has attempted to calibrate the Model 3100 with what appears to be a faulty sensor. Possible causes of fault code 15 are: incorrect or contaminated calibration gases, improper calibration procedure, or faulty sensor.

4.2.1.4 Fault Code 16 – Heater failure

The “heater failure” fault indicates that during warm-up, the sensor heater is not reaching expected temperatures within configured time tolerances set at the factory. Possible causes of fault code-14 are: sensor heater hardware failure, failure in sensor heater control interface, or sensor heater power supply voltage incorrect or missing.

4.2.2 Troubleshooting Common Problems with the RSM

4.2.2.1 Validating the analyzer reading

When encountering problems with inaccurate or erratic oxygen measurement, a good starting point is validating the reading to a known test gas source. With the Model 3100 analyzer in RUN mode, apply a Certified Standard Grade bottled gas to the RSM with oxygen concentration within the analyzer’s configured range. Wait for the reading on the analyzer 7-segment LED display to stabilize. Record the reading and match it against the oxygen concentration indicated on the test gas bottle certification tag.

4.2.2.2 Problem 1 – Display reads too high

4.2.2.2.1 Cause #1

Upset system condition indicates one of the following:

- ▶ Gas source contamination
- ▶ Gas delivery system integrity failure

- ▶ Insufficient time was given to allow a high concentration of oxygen in the sample gas to clear the sample line after startup, maintenance, or calibration

4.2.2.2.2 Solution #1

- ▶ Ensure the in-service sample gas source supply is open and gas is flowing through the sampling system
- ▶ Check gas delivery system for leaks and tighten or repair tubing connections
- ▶ Be certain to allow sufficient time for sample gases to purge out of the sample line when the model 3-LPM-N1-SS undergoes large step changes from high to low concentrations of oxygen

4.2.2.2.3 Cause #2

Improper calibration

4.2.2.2.4 Solution #2

If bump test reading is high, check calibration gases, verifying that they are within specifications. Perform 2-point calibration (see Model 3100 instruction manual).

4.2.2.3 Problem 2 – Display reads too low

4.2.2.3.1 Cause #1

Improper calibration or sensor is failing

4.2.2.3.2 Solution #1

- ▶ Check calibration gases, verifying that they are within specifications. Perform 2-point calibration (see Model 3100 instruction manual). If the sensor successfully calibrates but the reading drifts downward quickly, the sensor may be failing. Return Model 3100 analyzer and the RSM to the Neutronics factory for sensor replacement.
- ▶ Check the drift-rate by periodically performing a bump test. If the oxygen reading on a known gas source drifts downward below the stated accuracy tolerance (see Appendix B – Specifications) within a few weeks to a month, contact the Neutronics factory service team.

4.2.2.4 Problem 3 – Erratic or intermittent display

4.2.2.4.1 Cause #1

If line power has been temporarily interrupted, the analyzer will restart itself.

4.2.2.4.2 Solution #1

Provide the analyzer with an continuous power source during critical measuring periods. Provide a power line conditioner in areas where the mains power may experience fluctuations outside the listed specifications. It is recommended to install a Lightning Protection Unit (LPU) on the line power when the instrument is to be used in an area where lightning may create a high power surge on the instrument or induce noise into the power source.

4.2.2.4.3 Cause #2

Failure of an electronic component

4.2.2.4.4 Solution #2

In the event of a major component failure, return the analyzer and RSM to the Neutronics factory for repairs. Replacement of electronics components should only be attempted by a factory trained service technician.

5 Appendices

5.1 Appendix A – Spare parts list

Part number	Description
5-06-4900-18-0	Instruction manual
C6-01-1000-73-0	RSM / Analyzer interface cable – 3 meter with connectors
C1-11-1220-03-0	VAC Fuses – 4A, 250 VAC, Slo-Blo
C4-05-1300-01-0	40-micron in-line sample filter
1-10-0000-01-0	Power cord

5.2 Appendix B – Specifications

Item	Description
Sensor type	Rapid-response zirconium oxide, ZR100
Measurement range	0.1 PPM to 100% O ₂
Accuracy	± 2.0% of range @ STP
Response time	T ₉₀ < 5 seconds
Warm-up time	20 to 30 minutes
Humidity	0 to 95% non-condensing
Operating temperature	32° to 104° F (0° to 40° C)
Storage temperature	5° to 140° F (-15° to 60° C)
Sampling method	Extractive, via continuous positive pressure from sample source
Sample flow	1 LPM total at 6 PSIG sample inlet pressure
Sample pressure	6 to 20 PSIG regulated
Power	90–264 VAC, 47–63Hz, single phase, 250 Watts
Dimensions (LxWxH)	9.22" x 5.40" x 6.12" (234mm x 137mm x 155.4mm)
Weight	3 lbs. (1.36 kg)
Warranty	1 year from date of shipment

Specifications are subject to change without notice

6 Limited warranty

1. Because of the many and varied circumstances and conditions under which NEUTRONICS, INC.'s products are used, and because NEUTRONICS, INC. has no control over this actual use, NEUTRONICS, INC. makes no warranties which extend beyond the express provisions herein. NEUTRONICS, INC. MAKES NO IMPLIED WARRANTIES OF MERCHANTABILITY OR FITNESS. NEUTRONICS, INC. makes no express warranties beyond the following provisions, which only apply to the original purchaser.
2. NEUTRONICS, INC. only warrants to the original purchaser as follows: When the products and their component parts are properly installed and maintained in accordance with the published NEUTRONICS, INC. manuals, and if the product has not been modified or tampered with, then only the products actually manufactured by NEUTRONICS, INC. shall be warranted to be free from defects in material and workmanship for a period of one year from shipment by NEUTRONICS, INC., except NEUTRONICS, INC. sensors which shall be free of said defects for a period of time from date of shipment as specified in the NEUTRONICS INC. technical specifications for that specific sensor.
3. The original manufacturers' warranties apply to products and components not manufactured by NEUTRONICS, INC.

NON-ASSIGNABILITY OF WARRANTY

4. The warranty as set forth in these terms and conditions may not be assigned, transferred, sold, or alienated in any other way and extends only to the original purchaser.

PURCHASER'S EXCLUSIVE REMEDY

5. The original purchaser's sole and exclusive remedy, unless varied by written agreement with NEUTRONICS, INC., is that NEUTRONICS, INC. will, at NEUTRONICS, INC.'s option, repair or replace any defective part which is returned to NEUTRONICS, INC. within ninety (90) days of discovery of the defect.

DISCLAIMER OF CONSEQUENTIAL DAMAGES

6. In no event shall NEUTRONICS, INC. be liable for consequential damages, including but not limited to damages for loss of use, damages for lost profits, and damages for resulting harm to property other than the NEUTRONICS, INC. assemblies and their component parts.

Intended use for the Model 3-LPM-N1-SS

The Model 3-LPM-N1-SS RSM was designed to provide the trained operator with useful information relating to the concentration of Oxygen. This information may be used in process control applications to detect oxygen contamination. Before implementation, the user must fully understand the operation and limitations of this instrument as well as the application for its use. The responsibility for the proper application, operation, installation, and maintenance of the Model 3-LPM-N1-SS RSM is the sole obligation of the trained operator. The purchaser is required to ensure operators are properly trained in the use of this unit as well as in the possible hazards associated with its use or with the intended application. The purchaser must ensure that all of the proper warnings, labels, instruction manuals, lock outs, redundant components, hazard analysis, and system validation have been completed and provided to the trained operator before implementation of the Model 3-LPM-N1-SS RSM.