



A **BACHARACH** COMPANY

GRM₂ CO₂ REFRIGERANT MONITOR

Quick Install Guide



Caution - risk of electric shock



Please read this guide before installing the equipment

Important : All installation and maintenance work must be carried out by suitably qualified personnel only. All wiring must be carried out in accordance with latest NEC, CEC or IEC requirements and current local regulations

Doc Ref. QSGRM2C Rev3 20th March 2020

Revision	Details	Checked
2-0: 22nd Feb '17	Parasense Inc contact details updated. New format guide.	AK
2-1: 18th Jun '17	Parasense Inc address corrected.	AK
2-2: 8th Mar '18	Parasense logo updated	JB
Rev3	Address change	MC

Please also refer to the user manual for additional information.

The content of this manual is the copyright of PARASENSE and must not be copied or reproduced without their written permission.

Installation Guide

As the installation will require the disconnection and reconnection of main electrical circuits, work must be carried out by **SUITABLY QUALIFIED PERSONNEL ONLY**, and must be in accordance with the current regulations.

Four fixing brackets are supplied loose, choose orientation (horizontal / vertical), insert expanding nuts (if an internal fixed nut is not fitted) into holes in back of enclosure, push bolt through bracket to nut and tighten.

Mount the Monitor on a solid vertical surface in a non exposed area, in a position where the L.C.D screen can be easily and safely accessed, and where the Environmental Conditions are within;

Enclosure Dimensions

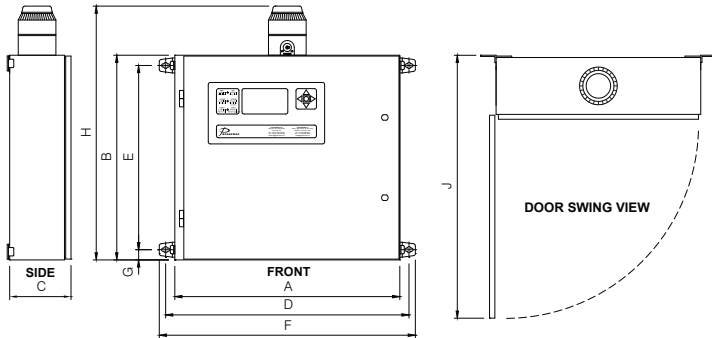

GRM2-104D2-CO2	A	B	C	D	E	F	G	H	J	WEIGHT
Metric (mm)	550	500	150	600	450	650	25	620	700	22kg
Imperial (In)	21.7	19.7	5.9	23.6	17.7	25.6	1.0	24.4	27.5	48.4lb

Electrical Requirements

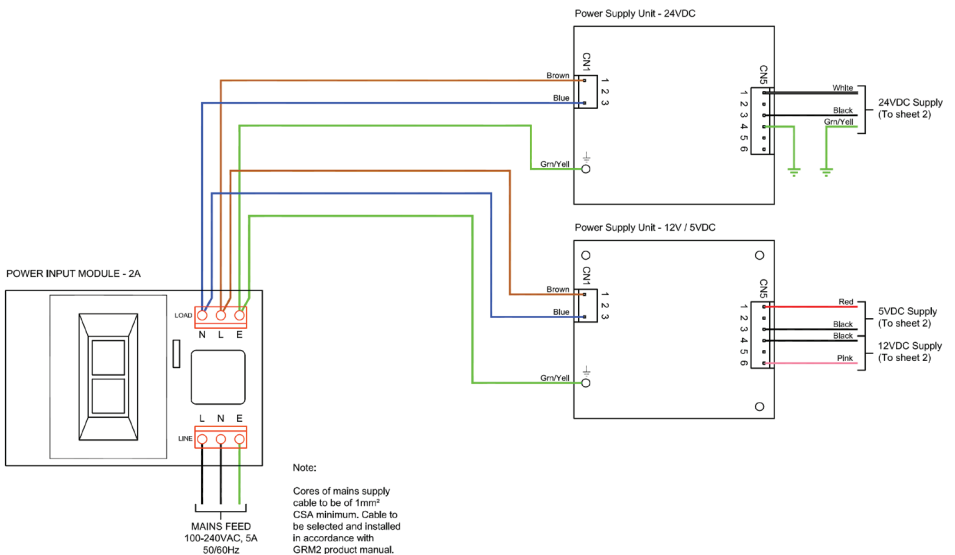

Each monitor requires an Earthed, AC single phase mains supply in the range 100 to 240 volts, 50 to 60 Hz, protected by a 5 amp fuse or similar over current circuit breaker. Power consumption for a GRM2 CO2 Monitor is 65 watts.

The final connection should be made as indicated, incorporating a water tight strain relief bush with a smoothly rounded opening, through the detector enclosure.

Cable used shall be RATED for the maximum current of the equipment, and shall be certified or approved by a recognized testing authority.

The cable anchorage shall relieve the conductors of the cable from strain, including twisting, where they are connected within the equipment, and shall protect the insulation of the conductors from abrasion. The protective earth conductor, if any, shall be the last to take the strain if the cable slips in its anchorage.

Cable anchorages shall meet the following requirements:

- a) The cable shall not be clamped by a screw which bears directly on the cable.
- b) Knots in the cable shall not be used.
- c) It shall not be possible to push the cable into the equipment to an extent which could cause a hazard.
- d) Failure of the cable insulation in a cable anchorage which has metal parts shall not cause accessible conductive parts to become hazardous live.
- e) It shall not be possible to loosen the cable anchorage without the use of a tool.
- f) It shall be designed so that cable replacement does not cause a hazard, and it shall be clear how the relief from strain is provided.

A compression bushing shall not be used as a cable anchorage unless it is suitable for use with the mains supply cable supplied with it or specified for it by the manufacturer.

Sampling Pipework Installation Guidelines

Installation - Do

- Maximum of one Spur Kit per SAMM.
- Maximum of 4 way split.
- Spur Kit Freeway pipe is always to be of equal length. No Exceptions.
- Ensure that the Freeway is pushed right into the connectors on the SAMM and Spur Kit branch connectors.
- Support and clip all Freeway and Spur Kit branch connectors.
- Ensure that the Spur Kit Freeway filters always point downwards.
- Attach identity markers to both ends of the Freeway.
- Use continuous lengths of Freeway (DO NOT JOINT).
- Sample points from a single SAMM must all be in the same room.
- Cut the Freeway straight using the correct cutter (supplied by Parasense).

Installation - Do Not

- Exceed 150m/500ft of Freeway (including all spur Freeway; E.g. for an installation with 100m/330ft of Freeway + 4-way 5m/16ft spur kit, the length would be 120m/394ft).
- Flatten or kink the Freeway.
- Bend the Freeway at a radius of less than 150mm/6".
- Run the Freeway from a warm place through a very cold space.
- Expose the Freeway or Spur Kit to temperatures in excess of 60°C/140°F, or less than -30°C/-22°F.
- Let the Spur Kit filters ever be immersed in water or any other liquids.
- Mix Spur Kit Freeway of different lengths on the same SAMM.
- Run Freeway in areas where they may be stood on or where they may restrict access to other equipment.

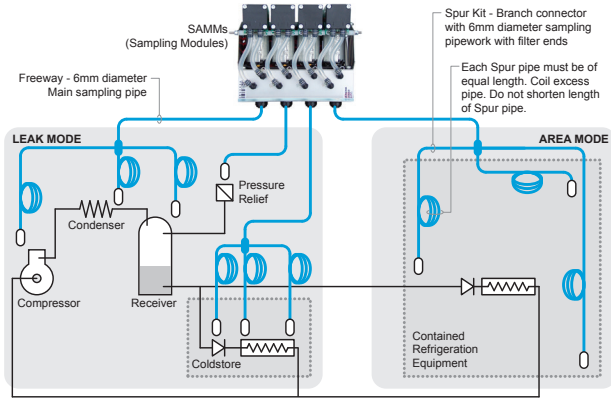

Typical installation incorporating spur kit

Factory Default Configuration Settings

Monitors are supplied programmed with Default Configuration Data. Modification can only be carried out via the Management menu of the door-mounted display.

Network settings

IP Address: 192.168.20.168
 Netmask: 255.255.255.0
 Server: 192.168.20.1
 Gateway: 192.168.20.1

SAMM Settings

Alert Level: 3000ppm Pipe Length: 150m/500ft
 Alarm Level: 5000ppm Refrigerant: CO2
 Critical Level: 15000ppm

Relay Settings

Relay 1 - 16: Any Critical

General Settings

Units: Metric
 Sample Interval: 30 Minutes

Channel Name/State

CHANNEL 1
 thru to
 CHANNEL 16

Relay Functions

16 separate volt-free changeover relays are fitted on the Main PCB, rated at 5 Amp (resistive). Contact voltages should not exceed 24V AC or DC.

Relays become energised when the Monitor is 'powered up' i.e. 'C' and 'NO' are linked. On loss of power or an alarm situation the relays become de-energised, i.e. 'C' and 'NC' are linked, 'C' and 'NO' are open circuit.

Relay 1 will de-energise if the PPM reading is in excess of the 'ALARM' level.

Relay 2 will de-energise if the PPM reading is in excess of the 'CRITICAL' level.

They will remain in their de-energised state until the PPM reading is below the appropriate levels.

If a fault relay has been allocated, this relay will de-energise if a fault is detected. The fault cause will be shown on the display screen, and the Green traffic light will go out. This condition will remain until the fault is rectified.

Contact

Parasense Limited

Phone: +44 (0) 1452 724123
 Email: salesuk@parasense.com
 Web: www.parasense.com

Parasense, Inc

Phone: +1 (540) 948 9919
 Email: sales@parasense.com
 Web: www.parasense.com