

**BACHARACH<sup>®</sup>**

# LEAKATOR<sup>®</sup> 10

INSTRUCTION 0019-9167  
COMBUSTIBLE GAS DETECTOR

Part No. 0019-7051

Rev. 18 – October 2012



## WARRANTY

Bacharach, Inc. warrants to Buyer that at the time of delivery this Product will be free from defects in material and manufacture and will conform substantially to Bacharach Inc.'s applicable specifications. Bacharach's liability and Buyer's remedy under this warranty are limited to the repair or replacement, at Bacharach's option, of this Product or parts thereof returned to Seller at the factory of manufacture and shown to Bacharach Inc.'s reasonable satisfaction to have been defective; provided that written notice of the defect shall have been given by Buyer to Bacharach Inc. within one (1) year after the date of delivery of this Product by Bacharach, Inc.

Bacharach, Inc. warrants to Buyer that it will convey good title to this Product. Bacharach's liability and Buyer's remedy under this warranty of title are limited to the removal of any title defects or, at the election of Bacharach, to the replacement of this Product or parts thereof that are defective in title.

THE FOREGOING WARRANTIES ARE EXCLUSIVE AND ARE GIVEN AND ACCEPTED IN LIEU OF (I) ANY AND ALL OTHER WARRANTIES, EXPRESS OR IMPLIED, INCLUDING WITHOUT LIMITATION THE IMPLIED WARRANTIES OF MERCHANTABILITY AND FITNESS FOR A PARTICULAR PURPOSE; AND (II) ANY OBLIGATION, LIABILITY, RIGHT, CLAIM OR REMEDY IN CONTRACT OR TORT, WHETHER OR NOT ARISING FROM BACHARACH'S NEGLIGENCE, ACTUAL OR IMPLIED. The remedies of the Buyer shall be limited to those provided herein to the exclusion of any and all other remedies including, without limitation incidental or consequential damages. No agreement varying or extending the foregoing warranties, remedies or this limitation will be binding upon Bacharach, Inc. unless in writing, signed by a duly authorized officer of Bacharach.

## **WARNING!**

*Because this instrument is used to detect and monitor materials and conditions which are listed by OSHA or others as potentially hazardous to personnel and property, the information in this manual must be fully understood and utilized to ensure that the instrument is operating properly and is both used and maintained in the proper manner by qualified personnel. An instrument that is not properly calibrated, operated and maintained by qualified personnel is likely to provide erroneous information, which could prevent user awareness of a potentially hazardous situation for the instrument user, other personnel and property.*

*If, after reading the information in this manual, the user has questions regarding the operation, application or maintenance of the instrument, supervisory or training assistance should be obtained before use. Factory assistance is available by calling 1-800-736-4666.*

## **WARNING!**

*The Leakator 10 is not to be used in any application that is beyond its intended purpose or beyond the scope of its specifications. Failure to follow this warning can result in personal injury or damage to the equipment. For details on appropriate use, refer to the general description, application, and operation discussions in this manual.*

# **CONTENTS**

---

	<b>Page</b>
1.0 INTRODUCTION .....	1
2.0 TECHNICAL CHARACTERISTICS.....	3
3.0 BATTERY INSTALLATION .....	5
4.0 OPERATION.....	6
4.1 Turning ON the Instrument.....	6
4.2 Taking a Gas Reading.....	6
4.3 Using the Earphone .....	8
4.4 Turning OFF the Instrument.....	8
5.0 MAINTENANCE .....	9
5.1 Replacing the Sensor.....	9
5.2 Replacing the Printed Circuit Board.....	12
5.3 Replacing the Speaker .....	13
5.4 Replacing the Flexible Probe Assembly.....	14
6.0 TROUBLESHOOTING.....	16
7.0 PARTS/SERVICE.....	17
7.1 Parts List .....	17
7.2 Bacharach Sales/Service Centers.....	20
8.0 DECLARATION OF CONFORMITY .....	21

## 1.0 GENERAL DESCRIPTION AND USE

The Leakator 10 is an intrinsically safe, battery-powered portable instrument designed to primarily detect the source of combustible-gas leaks. The instrument is ideally suited for heating service contractors, utility personnel, and other users who are interested in pinpointing gas leaks, and testing gas appliances in residential, commercial and industrial installations.

The instrument is supplied with a durable plastic carrying case, 20" probe and instruction manual.

The Leakator 10 features:

- Ten bright-red LEDs and a speaker that provide visual and audible indications to the presence of gas.



Figure 1. Leakator 10

- Three operation-status LEDs that show power on, sensor operation, and low battery.
- A 20-inch flexible probe.
- Simple thumb wheel on/off and gain control allowing one-handed operation.
- A solid-state sensor that has a typical life of 5 years.
- A battery capacity of 30 hours under normal use conditions.
- The ability to detect natural gas (methane) in concentrations as low as 20 ppm. In addition, the following gases and vapors are also detectable:

Acetone	Ethanol	Industrial Solvents
Acetylene	Ethylene Oxide	Paint Thinners
Ammonia	Gasoline	Propane
Benzene	Hexane	Naphtha
Butane	Hydrogen	

## WARNINGS!

*For safety reasons, the Leakator 10 must only be operated and serviced by qualified personnel. Read and understand the contents of this instruction manual before operating or servicing.*

*To prevent ignition of a hazardous atmosphere, do not perform any maintenance work, such as replacing the instrument's batteries, sensor, or sensor-matching resistor, in an area classified as being hazardous.*

## 2.0 TECHNICAL CHARACTERISTICS

<b>Power</b> .....	Five C-size Alkaline Batteries.
<b>Battery Life</b> .....	Approximately 30 hours of continuous operation under normal-use conditions.
<b>Sensor:</b>	
<b>Type</b> .....	Solid State, plug-in replacement.
<b>Life Expectancy</b> .....	Typically 5 years.
<b>Calibration</b> .....	No user calibration required.
<b>Probe</b> .....	Self storing 20" (51 cm) flexible probe, includes integral sensor.
<b>Response Time</b> .....	Less than 3 seconds to full scale indication.
<b>Sensitivity</b> .....	20 ppm Methane.
<b>Warm-Up Time</b> .....	Approximately 25 to 55 seconds.
<b>Duty Cycle</b> .....	Continuous with no limitation.
<b>Gas Indication</b> .....	Visual: 10 red ultra-bright LEDs. Audible: Variable speed ticking sound (earphone provided for use in noisy environments).
<b>Status LEDs</b> .....	Power On (green) Sensor Failure (yellow) Low Battery (yellow)

**Weight** ..... 17.8 oz (0.5 kg) (w/o batteries)

**Dimensions:** ..... 8.5" x 2.25" x 1.75"  
(21.6 x 5.7 x 4.4 cm)

**Operating**

**Environment:**

**Position** ..... Any

**Temperature** ..... 23° to 130°F (−5° to 54°C)

**Humidity** ..... 10% to 90% RH, non-condensing

**Safety Approvals** ..... Intrinsically Safe for use in Class I, Division 1, Groups A, B, C and D. CE Mark.

**3.0 BATTERY INSTALLATION**

**WARNING!**

*Do not replace batteries in a hazardous area.*

**CAUTION:**

*To maintain agency approval, use only NEDA-14A type batteries or equivalent.*

Remove battery cover. Install five (non-rechargeable) 1.5V C-size alkaline batteries per Figure 2 – observe proper polarity. Then reinstall battery cover.

**4.0 OPERATION**

**4.1 Turning ON the Instrument**

Turn ON the instrument by rotating its thumb-wheel switch



(Fig 3) clockwise until a click is heard. Observe the following:

- The Power LED lights.
- The Fail LED will light, but should turn off in a few seconds if the sensor is good and properly seated in its socket.
- If the Low Bat. LED is on, replace the batteries per Section 3.0 *Battery Installation*.

After the instrument stabilizes, rotate the Gain control in the direction necessary to cause the bottom Gas Level LED to just turn off. Be sure to always set this control in the same environment you intend to test in.

The instrument is now ready for use.



*Figure 2. Battery Installation*

## 4.2 Taking a Gas Reading

To verify that the instrument is operating, sample a known combustible gas (e.g., a gas-air mixture from an unlit burner of a natural-gas range). If no response is observed or heard, refer to Section 6.0 *Troubleshooting*.

**Important!** *The sensor becomes less sensitive after being exposed to an excessive amount of gas. Therefore, after testing the instrument as described above, leave it on for several minutes to restabilize the sensor.*

Take a gas reading by positioning the end of the instrument's flexible probe near the area to be sampled.

The presence of a combustible gas is indicated by a column of ten red LEDs and a speaker. The number of lighted LEDs gives visual indication of the relative gas level, while the speaker produces clicking sounds, similar to a Geiger counter, that increase in repetition rate as the gas concentration goes up in relation to the instrument's gain setting.

The instrument's sensitivity to gas concentrations is adjusted by means of its thumb-wheel **Gain** control. Clockwise rotation increases sensitivity, while counterclockwise rotation decreases sensitivity. The **Gain** control is useful in pinpointing large leaks by starting with the control set to light 1 or 2 LEDs, and then gradually rotating the control counterclockwise as the probe gets closer to the leak.

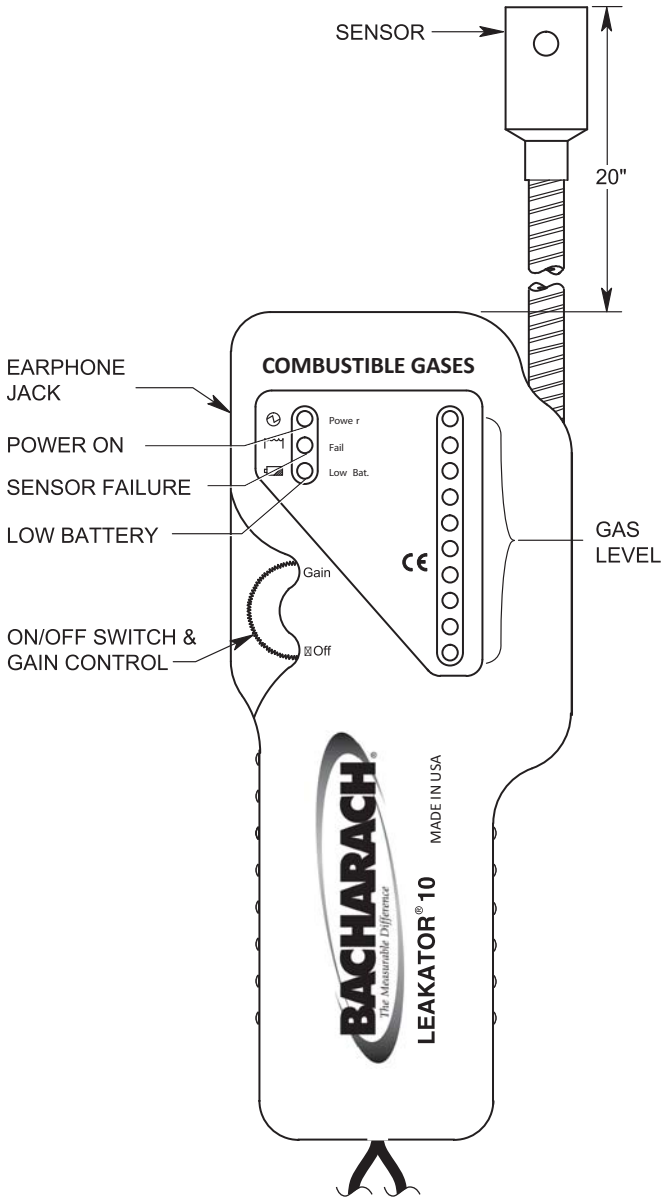

Figure 3. Jack, Control, and Indicators

## 4.3 Using the Earphone

The earphone is an optional accessory that provides private monitoring of the Leakator 10, and is recommended for use in high-noise environments. The earphone plugs into the side of the instrument, just above the thumb-wheel control.

## 4.4 Turning OFF the Instrument

Turn OFF the instrument by rotating the thumb-wheel control counterclockwise until a click is heard. There is no need to purge the instrument with fresh air before turning it off.

## 5.0 MAINTENANCE

### WARNING!

*Do not replace the batteries, sensor, or sensor matching resistor in a hazardous area.*

Since the Leakator 10 does not require calibration at regular intervals, very little needs to be done to maintain the instrument in working order.

If the instrument has not been used for more than 3 months, you may wish to turn it on and let it run in fresh air for several minutes to keep the sensor at peak sensitivity.

If a problem should occur with your instrument, refer to Section 6.0 *Troubleshooting*.

Detailed procedures of how to replace the sensor and other components in the instrument are provided below.

## 5.1 Replacing the Sensor

Replacement sensors are classified at the factory according to sensitivity, and are shipped with a matching resistor that ensures the sensor will function properly when installed in your instrument. It is important that the sensor and its resistor be used together – DO NOT intermix resistors and sensors.

### Items required:

- Small and medium flat-blade screwdrivers
- Wire cutter
- Replacement sensor with matching resistor (P/N 0019-0398)

### Procedure:

1. Turn OFF instrument.
2. Pry sensor out of its socket using a small flat-blade screwdriver (Fig 4) and discard.
3. Remove battery cover.
4. Remove old matching resistor (Fig 5) and discard.
5. Locate new sensor's matching resistor; then cut and bend the resistor leads using the forms that are molded into the battery cover (Fig 6). *Note that If the resistor leads are cut too short, the instrument may not function.*
6. Insert new matching resistor into printed circuit board, and plug new sensor into socket at end of probe. *Notice that the sensor's six pins and the socket are symmetrical and not keyed, thus permitting the sensor to be plugged in two ways. The socket, however, is wired so that it doesn't matter which way the sensor is installed.*
7. Install battery cover.
8. Test instrument response (refer to Section 4.2).

## 5.2 Replacing the Printed Circuit Board

### Items required:

- Medium flat-blade screwdriver
- Medium Phillips screwdriver
- Replacement printed circuit board (P/N 0019-0418)

### Procedure: (See Figure 7)

1. Turn OFF instrument and lay it face down on work area.
2. Remove battery cover and batteries.
3. Remove sensor-matching resistor.
4. Remove four screws securing rear case.
5. Carefully lift rear case and flexible arm assembly away from instrument, being careful not to pull wires attached to printed circuit board. Lay rear case face down on work area.
6. Carefully remove printed circuit board from front case.
7. Unplug connectors J2 and J3 from printed circuit board.
8. Plug connectors J2 and J3 into new printed circuit board; then install board into front case.



Pry sensor from its socket using a small flat-blade screwdriver inserted through access hole.

*Figure 4. Removing Sensor*

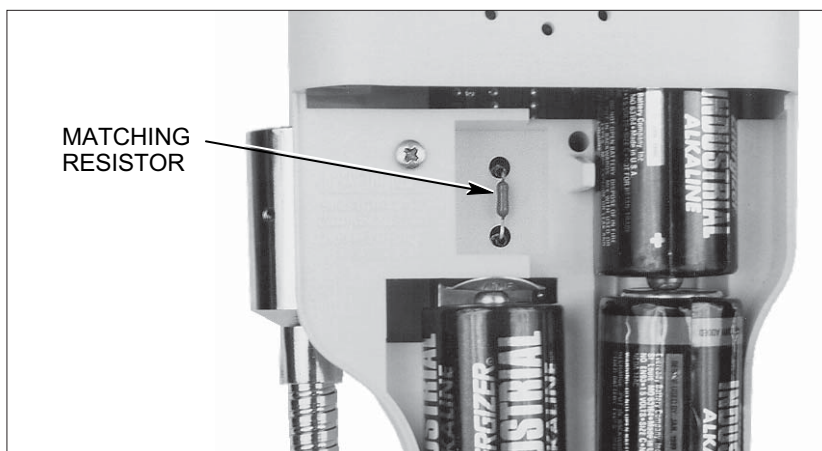

Figure 5. Location of Matching Resistor

Cut Matching Resistor leads to correct length by inserting each lead into form as shown and cutting here.

**NOTE:** The plastic clip guide length represents the minimum lead length. If the resistor leads are cut too short, the instrument may not function.

Optimum lead length is 11/16".

After cutting resistor leads, use this form to bend leads as shown.

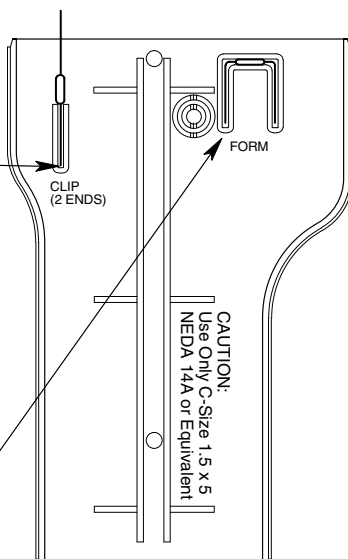

Figure 6. Cutting and Bending Resistor Leads using Forms Molded into Battery Cover

9. Install flexible arm assembly and rear case using the screws that were removed in Step 4.
10. Replace sensor-matching resistor.
11. Replace batteries and battery cover.
12. Test instrument response (refer to Section 4.2).

### 5.3 Replacing the Speaker

#### Items required:

- Medium flat-blade screwdriver
- Medium Phillips screwdriver
- $1\frac{1}{32}$ " Nut driver
- Replacement speaker (P/N 0019-0400)

#### Procedure: (See Figure 7)

1. Turn OFF instrument; then remove battery cover and batteries.
2. Remove sensor-matching resistor.
3. Remove four screws securing rear case; then carefully lift rear case and flexible arm assembly away from instrument, being careful not to pull wires attached to printed circuit board. Lay rear case face down on work area.
4. Carefully remove printed circuit board from front case; then unplug speaker connector J2 from printed circuit board.
5. Remove two nuts and washers securing speaker to rear case; then remove speaker.
6. Install new speaker and secure in place using the nuts and washers that were removed in Step 5. *CAUTION! Do not overtighten the nuts!*



7. Replace flexible arm assembly and rear case using the screws that were removed in Step 3.
8. Replace sensor-matching resistor.
9. Replace batteries and battery cover.
10. Test instrument response (refer Section 4.2).

## 5.4 Replacing the Flexible Probe Assembly

### Items required:

- Medium flat-blade screwdriver
- Medium Phillips screwdriver
- Replacement flexible probe assembly (P/N 0019-3091)

### Procedure: (See Figure 7)

1. Turn OFF instrument and lay it face down on work area.
2. Remove battery cover and batteries.
3. Remove sensor-matching resistor.
4. Remove four screws securing rear case.
5. Carefully lift rear case and flexible arm assembly away from instrument, being careful not to pull wires attached to printed circuit board. Lay rear case face down on work area.
6. Carefully remove printed circuit board from front case.
7. Unplug sensor connector J3 from printed circuit board.
8. Remove flexible probe assembly and remove sensor.

9. Plug connector on new flexible probe assembly into printed circuit board connector J3.
10. Replace printed circuit board, new flexible probe assembly, and rear case using the screws that were removed in Step 4.
11. Replace sensor.
12. Replace sensor-matching resistor.
13. Replace batteries and battery cover.
14. Test instrument response (refer to Section 4.2).

## 6.0 TROUBLESHOOTING

### WARNING!

*Do not perform any maintenance work in a hazardous area.*

Because of the Leakator 10's advanced design, trouble with the instrument can usually be diagnosed by looking at the LEDs as seen through the front-case. See Figure 3.

If the Fail LED lights, check that the sensor is seated and J3 is connected to the printed circuit board. If still no change, replace the sensor per Section 5-1 *Replacing the Sensor*.

If the Low-Bat. LED lights, replace the batteries per Section 3.0 as soon as possible. The instrument should operate, however, for several hours before the batteries go dead.

If the instrument doesn't respond to a combustible gas, perform the following in the order presented until the problem is corrected:

- First ensure that all connectors are securely in place on the printed circuit board, and that the sensor is firmly seated into its socket.
- Replace sensor, even though the Sensor-Fail LED isn't on, per Section 5.1 *Replacing the Sensor*.
- Replace circuit board per Section 5.2 *Replacing the Printed Circuit Board*.

## 7.0 PARTS/SERVICE

### 7.1 Parts List

#### Replacement Parts (See Fig 7)

Item	Description	Part No.
1	Battery Cover (2 Screws)*	0019-0405
2	Nut, Palnut Fastner	0102-3736
3	Flexible Probe Assembly (4 Wire)**	0019-3091
4	Front Case	0019-0392
5	Printed Circuit Board Assembly	0019-0418
6	Rear Case	0019-0449
7	Replacement Sensor with Matching Resistor***	0019-0398
8	Screw, #4-20 x ¾ thd. forming	0102-1976
9	Speaker Assembly	0019-0400
10	Washer, #10 Plain	0002-4140
11	Wrist Strap	0019-0443
---	Instruction Manual	0019-9167

\* Call factory if your battery cover has only 1 screw.

\*\* Call factory if your probe assembly has 3 wires.

\*\*\* Available only as a matched set.

#### Accessories

Description	Part No.
Carrying Case	0019-0397
Earphone	0004-9910

## 7.2 Bacharach Sales/Service Centers

### **United States**

---

Bacharach, Inc.  
621 Hunt Valley Circle  
New Kensington, PA 15068  
Phone: 1-800-736-4666  
Fax: 724-334-5723  
Email: help@mybacharach.com

### **Canada**

---

Bacharach of Canada, Inc.  
20 Amber St. Unit #7  
Markham, Ontario L3R SP4  
Canada  
Phone: 905-470-8985  
Fax: 905-470-8963  
Email: bachcan@idirect.com

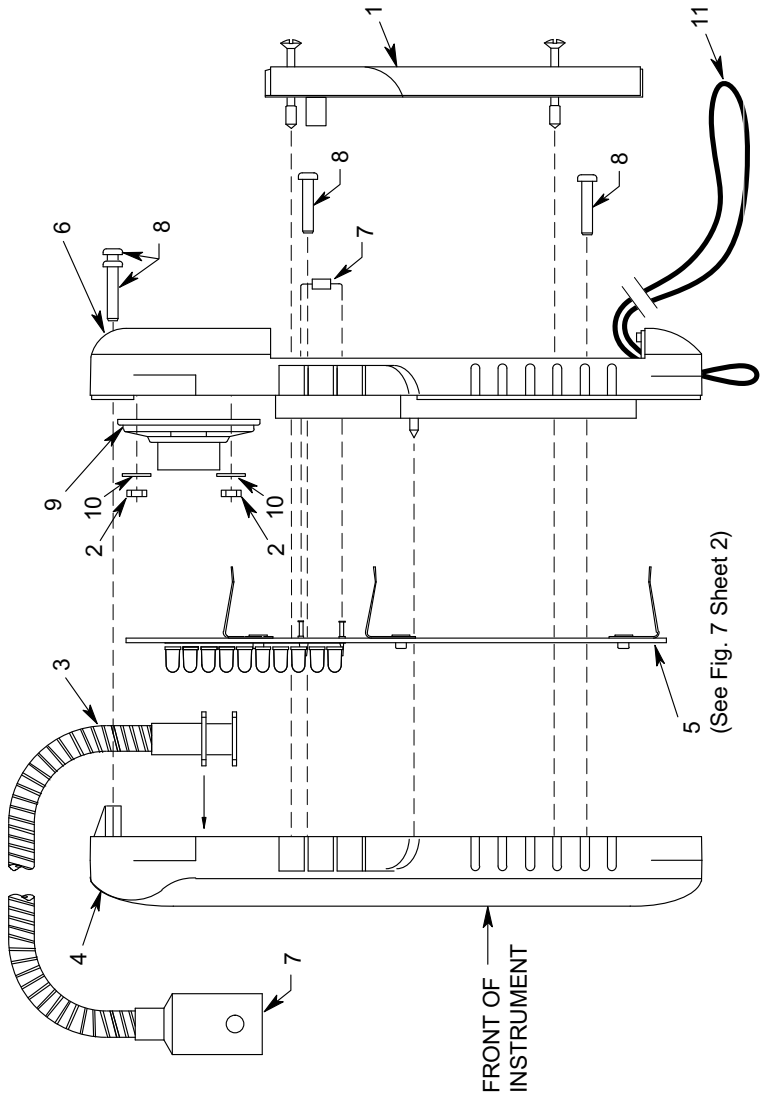

Figure 7. Leakator 10 Part Locations (Sheet 1 of 2)

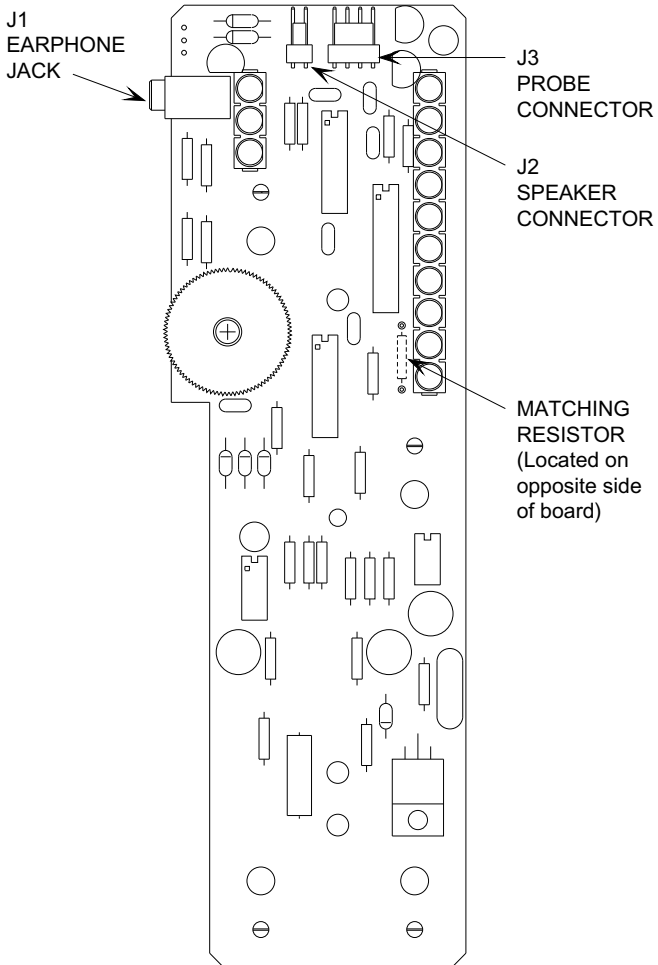

Figure 7. Leakator 10 Part Locations (Sheet 2 of 2)





# 8.0 Declaration of Conformity



<b>The manufacturer of the products covered by this declaration:</b>	Bacharach, Inc. 621 Hunt Valley Circle New Kensington, PA 15068
<b>Year(s) conformity is declared:</b>	2010 (EN 50270: 2006)
<b>Product(s):</b>	Combustible Gas Leak Detector
<b>Model(s):</b>	Leakator 10

The undersigned hereby declares that the above referenced products are in conformity with the provisions of the following standards and is in accordance with the following directive.

**Directive(s):**

2004/108/EC	EU EMC Directive
-------------	------------------

**Standard(s):**

EN 50270: 2006	Electromagnetic Compatibility (EMC) Standards	Electrical Apparatus for the Detection and Measurement of Combustible Gases, Toxic Gases, or Oxygen
----------------	---	---

Signature: 

Name: Doug Keeperts  
 Title: VP of Product Development  
 Date: 26 October 2010

The technical documentation file required by this directive is maintained at the corporate headquarters of Bacharach, Inc.







**Bacharach, Inc.**

621 Hunt Valley Circle, New Kensington, PA 15068

Ph: 724-334-5000 • Fax: 724-334-5001 • Toll Free: 800-736-4666

Website: [www.mybacharach.com](http://www.mybacharach.com) • E-mail: [help@mybacharach.com](mailto:help@mybacharach.com)



Printed in U.S.A.

® Registered Trademarks