



# MGS-150

## GAS DETECTOR INSTALLATION GUIDE

P/N: 6309-9002  
Revision 1  
October 2016



**CAUTION:** DO NOT MOUNT the MGS-150 in an area that may contain flammable liquids or vapors. Operation of electrical equipment in such an area constitutes a safety hazard.



**WARNING:** Strictly follow the instructions in the Gas Detector Manual (part number 6309-9000) available at [www.MyBacharach.com](http://www.MyBacharach.com).

### 1: OPERATING AREA AND CONDITIONS

The Bacharach MGS-150 is an instrument for the continuous monitoring of refrigerant, combustible, and toxic gases.

The instrument is powered by 12-24V AC or DC (selectable by an on-board jumper). The output signal can be selected as either voltage or current. The on-board relay can be used to switch alarm devices.

### 2: SAFETY INSTRUCTIONS

**USER MANUAL:** Before using this equipment, carefully read and strictly follow the User Manual (part number 6309-9000). The user must fully understand and strictly observe the instructions. Use the equipment only for the purposes listed and under the conditions specified in those documents.

**CODE COMPLIANCE:** Comply with all local and national laws, rules and regulations associated with this equipment.

**GENUINE PARTS:** Use only genuine Bacharach spare parts and accessories, otherwise proper functioning of the equipment may be impaired.

**TECHNICIAN USE ONLY:** This unit must be installed by a suitably qualified technician who will install this unit in accordance with these instructions and the standards in their particular industry/country. Operators of the unit should be aware of the regulations and standards in their industry/country for the operation of this unit. These notes are only intended as a guide and the manufacturer bears no responsibility for the installation or operation of this unit.

Failure to install and operate the unit in accordance with these instructions and with industry guidelines may cause serious injury including death and the manufacturer will not be held responsible in this regard.

**SAFE MOUNTING:** This monitor must be connected by a marked, suitably located and easily reached switch or circuit-breaker as means of disconnection.

### 3: WEIGHTS AND DIMENSIONS

Type/Enclosure	Dimensions	Weights
IP41	3.35" x 5.59" x 2.09" 86 x 142 x 53 mm	6.3 oz 180 g
IP66	6.89" x 6.5" x 3.29" 175 x 165 x 82 mm	1 lb 6 oz 629 g
IP66 w/ Splash Guard	6.89" x 8.9" x 3.29" 175 x 225 x 82 mm	1 lb 9 oz 700 g
IP66 w/ Remote Sensor	6.89" x 6.1" x 3.29" 175 x 155 x 82 mm	1 lb 11 oz 790 g
IP66 w/ Ex d Remote Head	6.89" x 6.1" x 3.29" 175 x 155 x 82 mm	2 lb 10 oz 1185 g
IP66 w/ PRV Sensor Head	6.89" x 6.1" x 3.29" 175 x 155 x 82 mm	2 lb 0.3 oz 916 g
IP66 Airflow/Duct (See Table)	6.89" x 4.9" x 3.29" 175 x 125 x 82 mm	1 lb 4 oz 578 g
Ex d (Enclosure)	5.8" x 7.1" x 5.0" 147 x 180 x 128 mm	4 lb 10 oz 2100 g

#### Supported CFM & Duct Sizes for Duct Mount Housing

Units	Duct Size				
	Inches	Feet	Area (ft <sup>2</sup> )	Area (ft <sup>2</sup> )	Area (ft <sup>2</sup> )
Inches	12 x 12	12 x 24	18 x 18	24 x 24	24 round
Feet	1 x 1	1 x 2	1.5 x 1.5	2 x 2	Pi x 1 x 1
Area (ft <sup>2</sup> )	1	2	2.25	4	3.14

### 4: MOUNTING

**ENVIRONMENTAL CONSIDERATIONS:** Carefully consider the full range of environmental conditions to which the instruments will be exposed.

**TARGET GAS CONSIDERATIONS:** The physical data of the gas or vapor to be detected must be observed.

**APPLICATION CONSIDERATIONS:** The specifics of the application (for example, possible leaks, air movement/draft, etc.) must be observed.

**ACCESSIBILITY CONSIDERATIONS:** The degree of accessibility required for maintenance purposes must be granted.

**ACCESSORY CONSIDERATIONS:** The types of optional and accessory equipment that will be used with the system must be kept in mind.

**ELECTRONIC CONSIDERATIONS:** The system contains sensitive electronic components that can be easily damaged. Do not touch nor disturb any of these components.

Mount the MGS-150 according to the above considerations, product dimensions (see Section 3), maximum wiring lengths (see Section 3), maximum wiring lengths (see Section 5), and the corresponding mounting dimensions shown in the illustrations that follow.

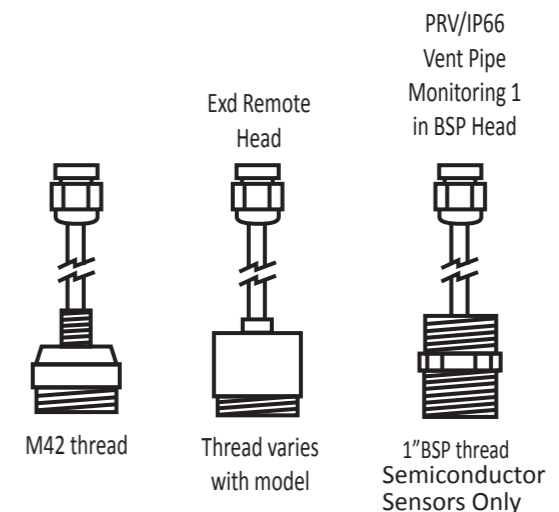
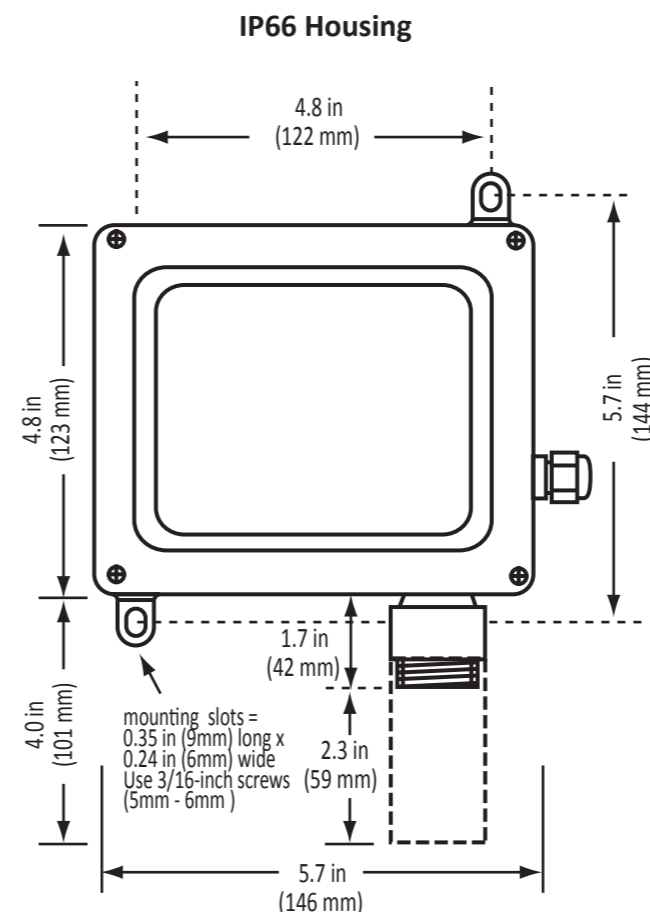
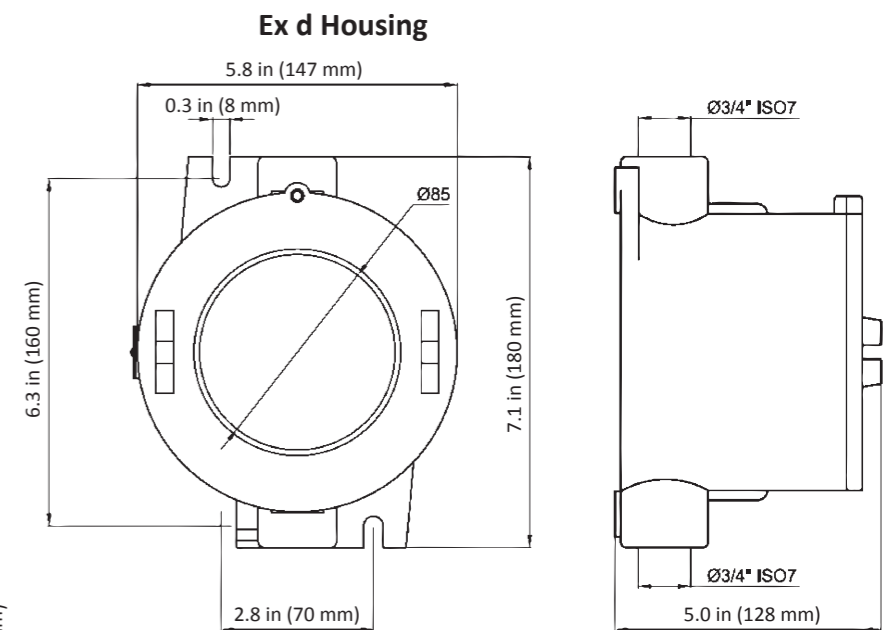
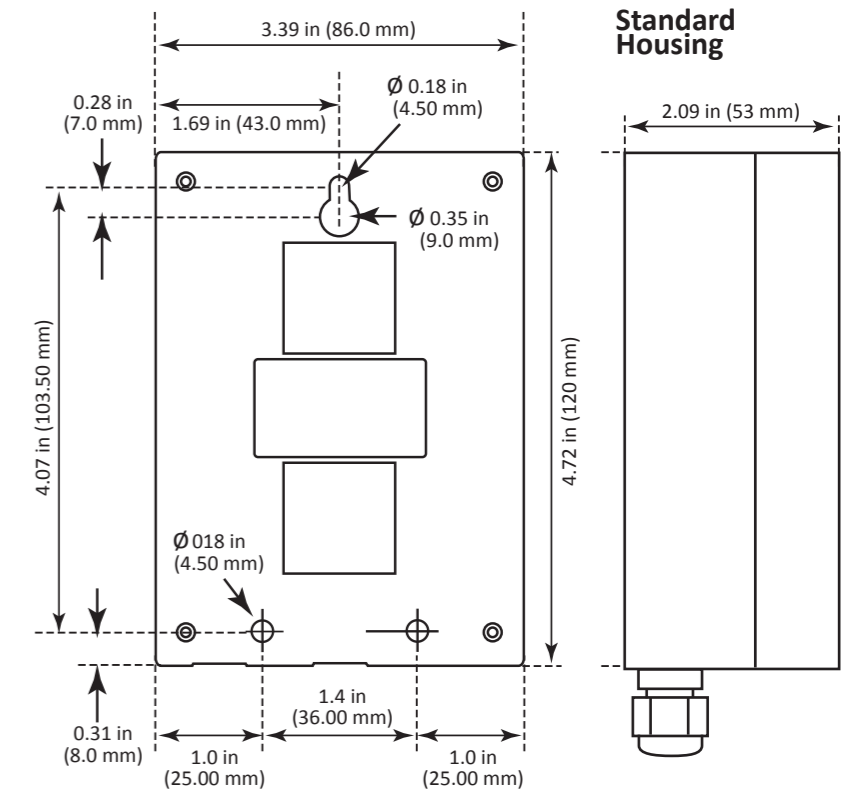

PRV/IP66 Vent Pipe Monitoring 1 in BSP Head

Exd Remote Head

M42 thread

Thread varies with model

1" BSP thread Semiconductor Sensors Only

## 5: WIRING AND CONFIGURATION

**CABLE OPENINGS:** Each MGS-150 IP41 transmitter will have a single opening for a PG7 cable gland, as well as an optional knockout opening. Each MGS-150 IP66 transmitter has 3 openings. These openings can be used for field wiring, direct attachment of a sensor or wiring of a remote sensor. Unused openings must be closed with a suitable plug and gasket, maintaining the IP or Ex d rating.

**NOTE:** To make wiring connections, you must first open the MGS-150 housing. The enclosure lid of the IP66 housing has four captive screws.

Refer to the User Manual (part number 6309-9000) at [www.MyBacharach.com](http://www.MyBacharach.com) for detailed instructions on accessing the internal components for wiring.

**NOTE:** For AC-powered configurations, ensure that the AC neutral supply line is not used as the ground reference for the analog outputs.

**NOTE:** After wiring is completed, carefully re-assemble the enclosure and its components, noting the keyed ribbon cable and sensor connectors. After installation is complete, be sure to refer to the User Manual (part number 6309-9000) at [www.MyBacharach.com](http://www.MyBacharach.com) for detailed instructions on registering the sensors and configuring the MGS-150 for proper operation.

**IMPORTANT CONFIGURATION NOTE:** For detection of R449A or R450A, the maximum linear range of 500 ppm equals 50% of the range of the analog output (e.g., 500 ppm = 12 mA, when using 4-20mA output). Data above this range should be discarded as invalid. The alarm set point must not be adjusted higher than 500 ppm for these gases.



World Headquarters  
621 Hunt Valley Circle  
New Kensington, PA 15068 USA  
Phone: 724-334-5000 • Fax: 724-334-5001  
Toll Free: 1-800-736-4666  
Website: [www.MyBacharach.com](http://www.MyBacharach.com)  
E-mail: [help@MyBacharach.com](mailto:help@MyBacharach.com)

114A Georges Street Lower  
Dun Laoghaire • Co Dublin • Ireland  
Phone: +353 1 284 6388 • Fax: +353 1 284 6389

## Electrochemical (EC) or Infrared (IR) Sensor

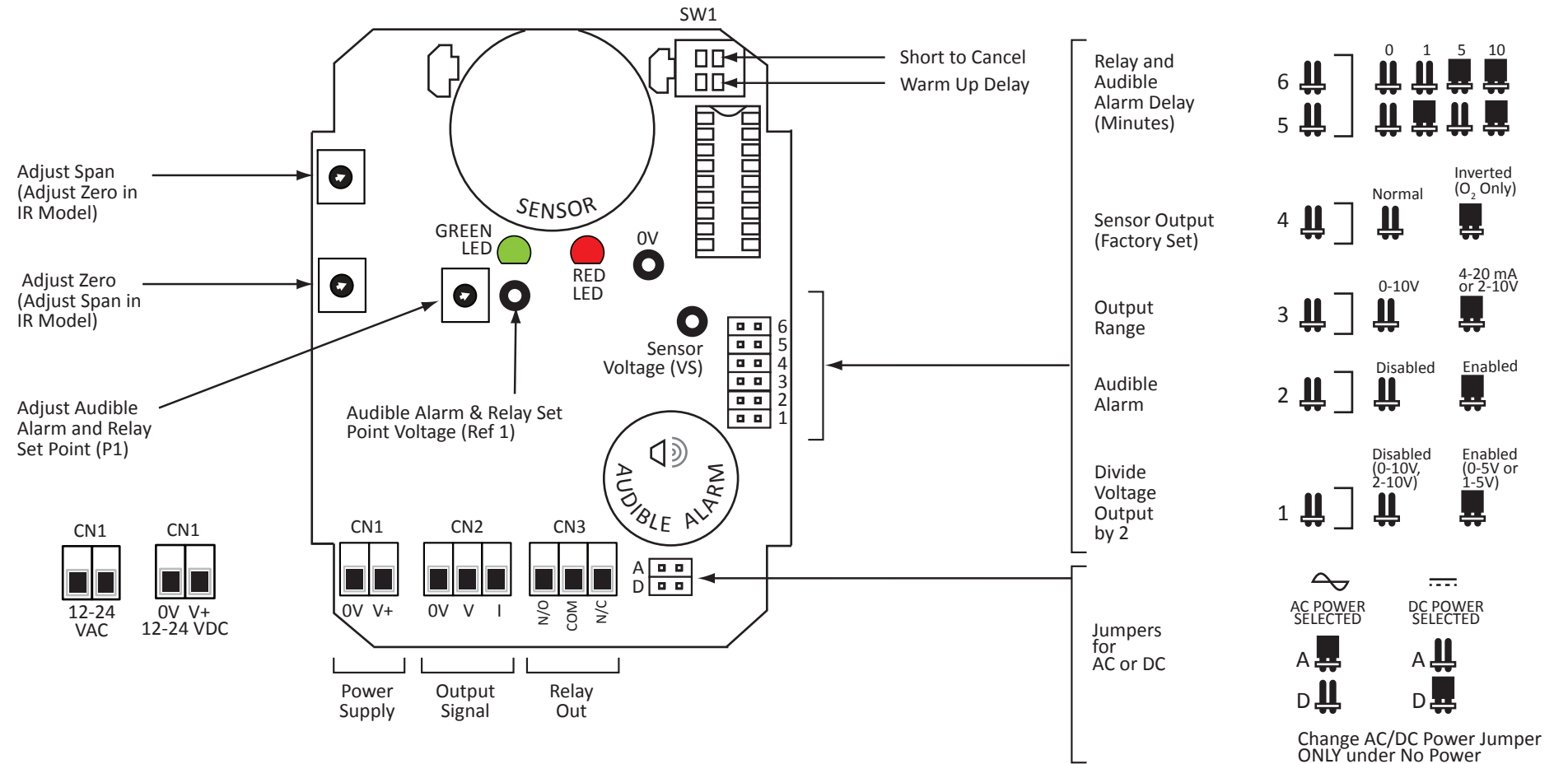

## Semiconductor (SC) Sensor

